

ALIGNMENT: SVP-E
 7-20-10
 DA
 SHEET 1 OF 15

NOTE: MODEL DOES NOT INCLUDE THE FOLLOWING:
 AB UNDER MEDIAN CURB
 AB LIMITS OFFSET FROM SAWCUT
 FINISHED GRADE BETWEEN MEDIAN CURBS

SILVA VALLEY PARKWAY WIDENING SOUTH OF ENTRADA DRIVE #72370
 EL DORADO COUNTY DEPARTMENT OF TRANSPORTATION



PREPARED UNDER THE SUPERVISION OF :

Dwight G. Anderson

REGISTERED CIVIL ENGINEER

7-20-10
 DATE:

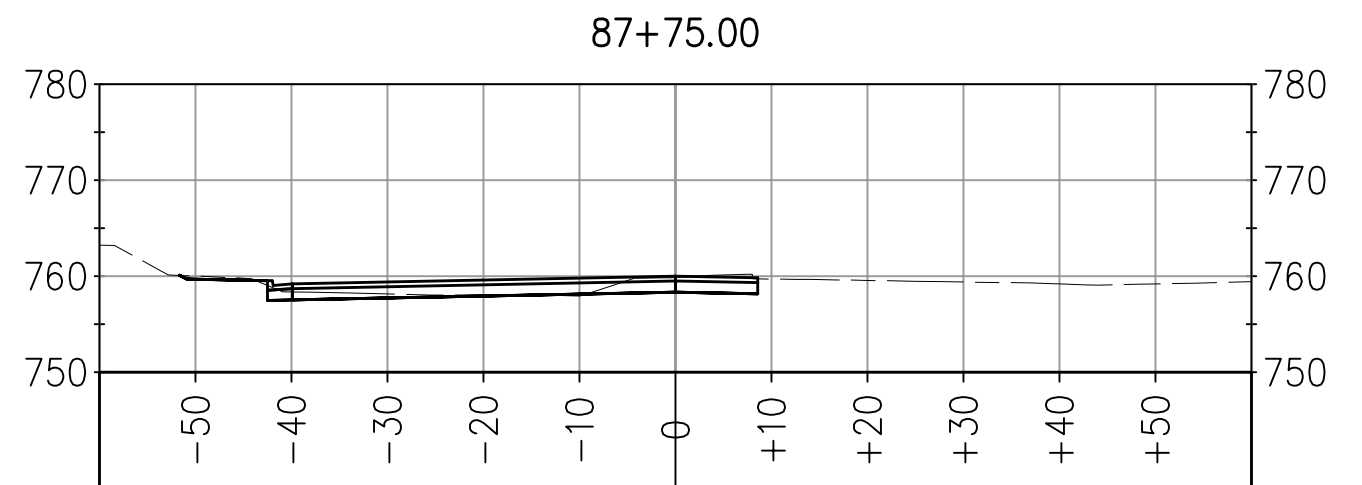
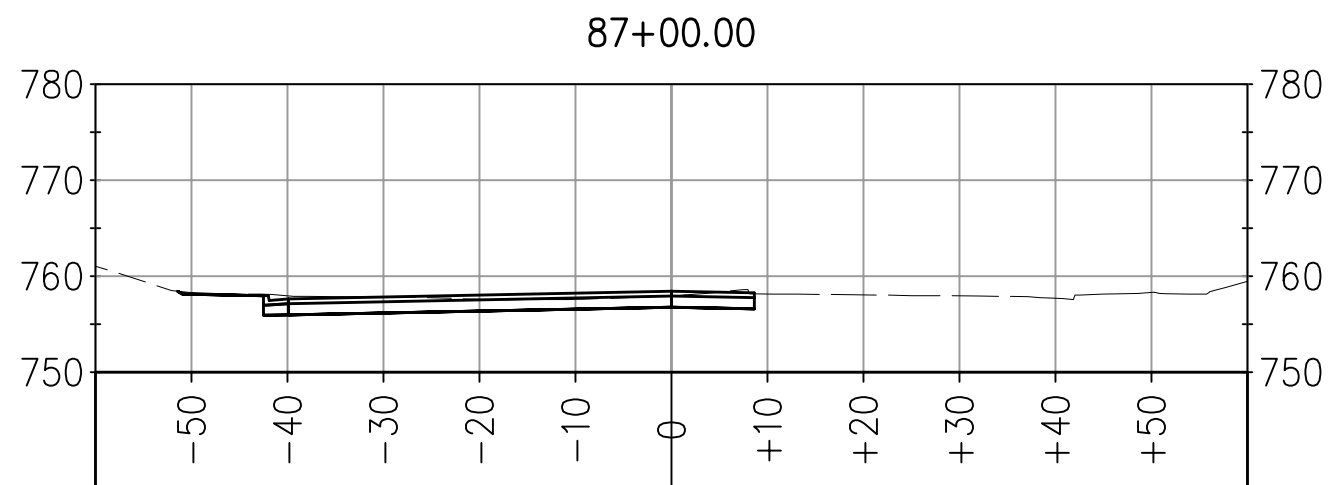
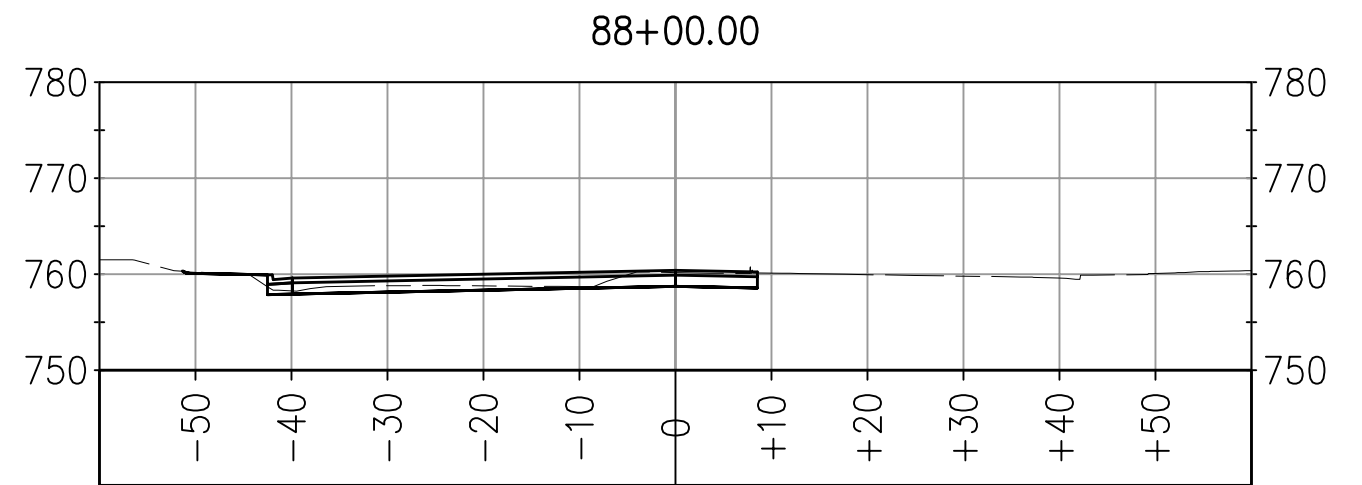
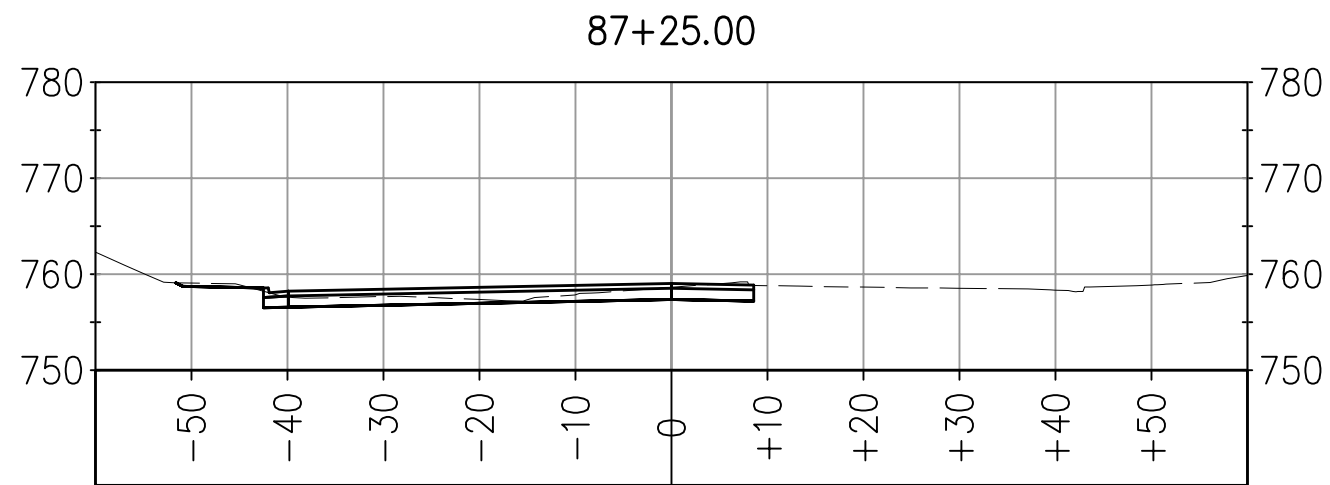
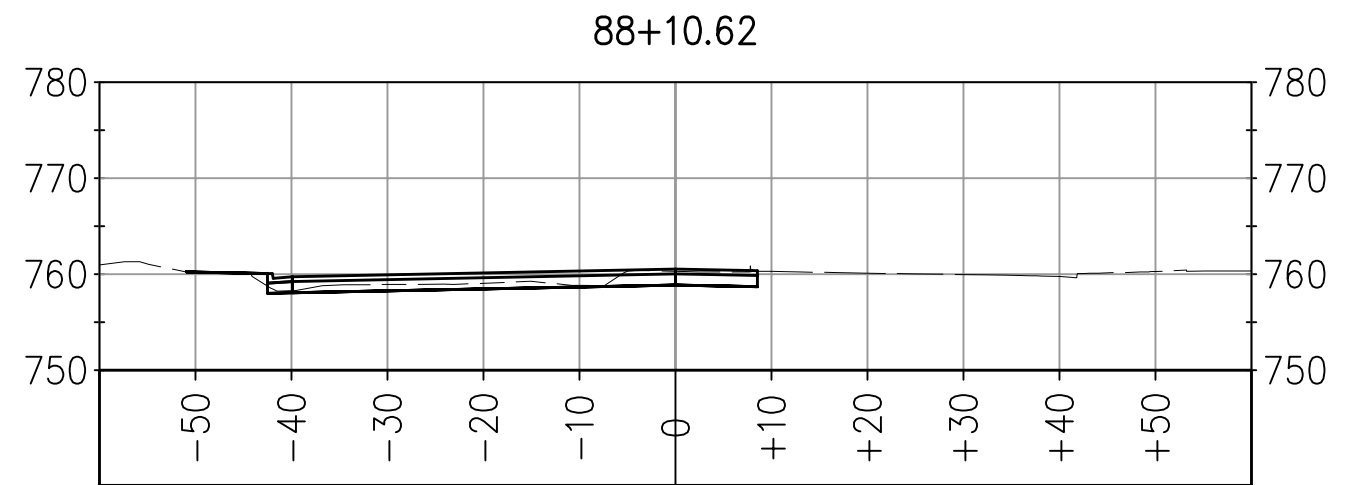
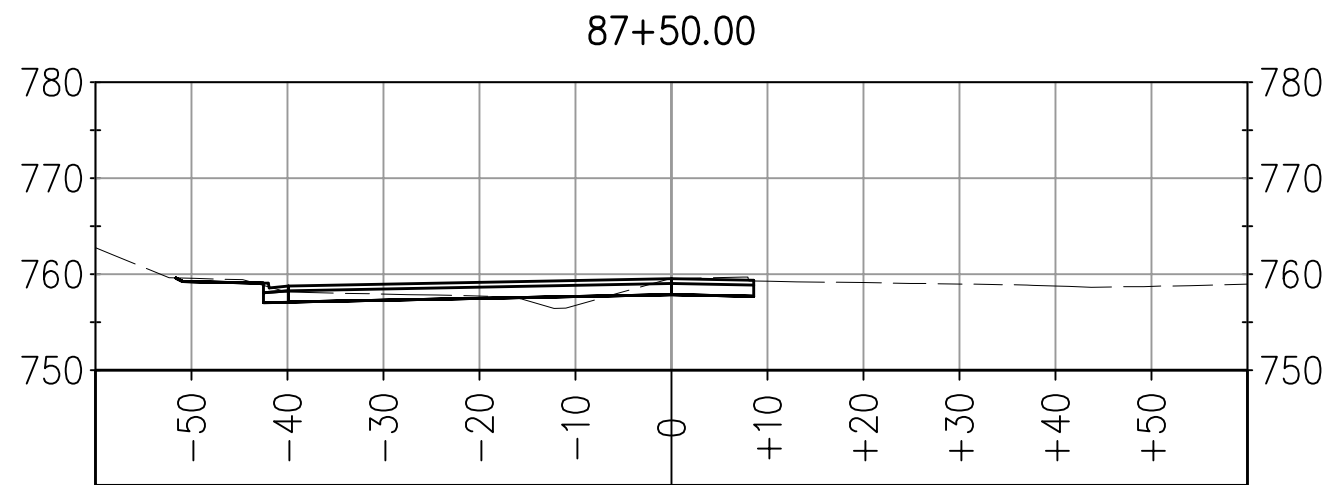

ALIGNMENT: SVP-E
 7-20-10
 DA
 SHEET 2 OF 15

NOTE: MODEL DOES NOT INCLUDE THE FOLLOWING:
 AB UNDER MEDIAN CURB
 AB LIMITS OFFSET FROM SAWCUT
 FINISHED GRADE BETWEEN MEDIAN CURBS

SILVA VALLEY PARKWAY WIDENING SOUTH OF ENTRADA DRIVE #72370
 EL DORADO COUNTY DEPARTMENT OF TRANSPORTATION

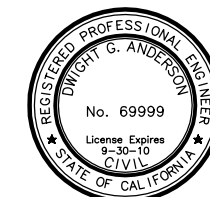

PREPARED UNDER THE SUPERVISION OF:
Dwight G. Anderson
 REGISTERED CIVIL ENGINEER
 DATE: 7-20-10

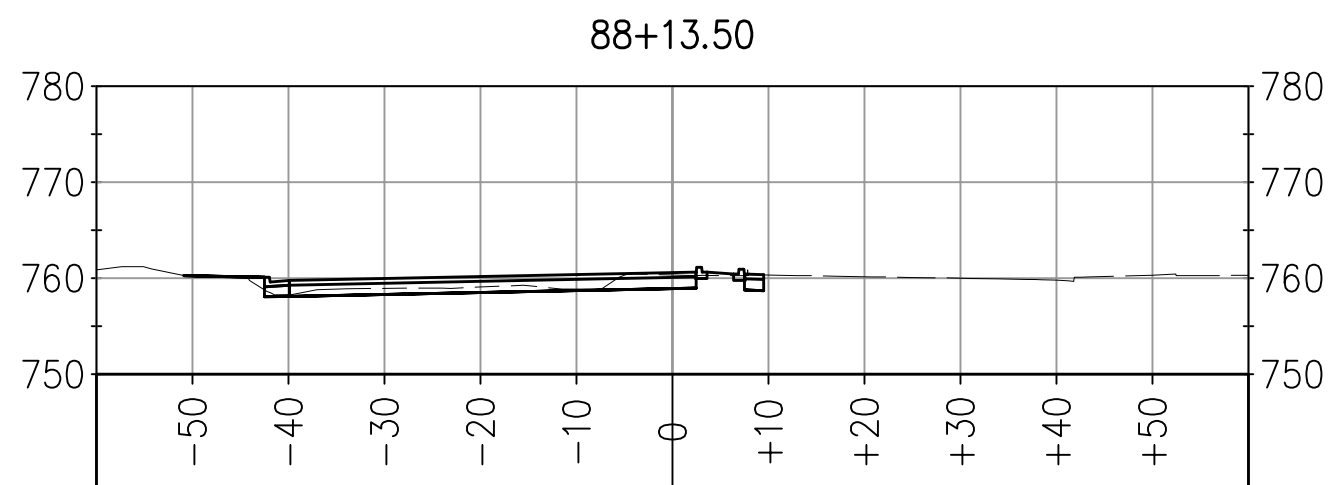
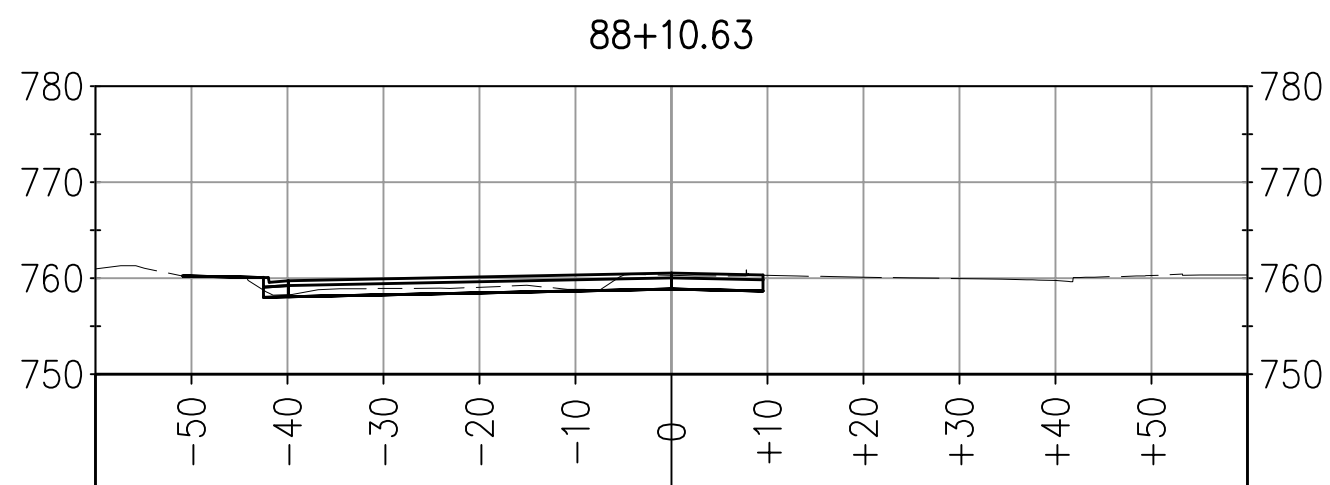
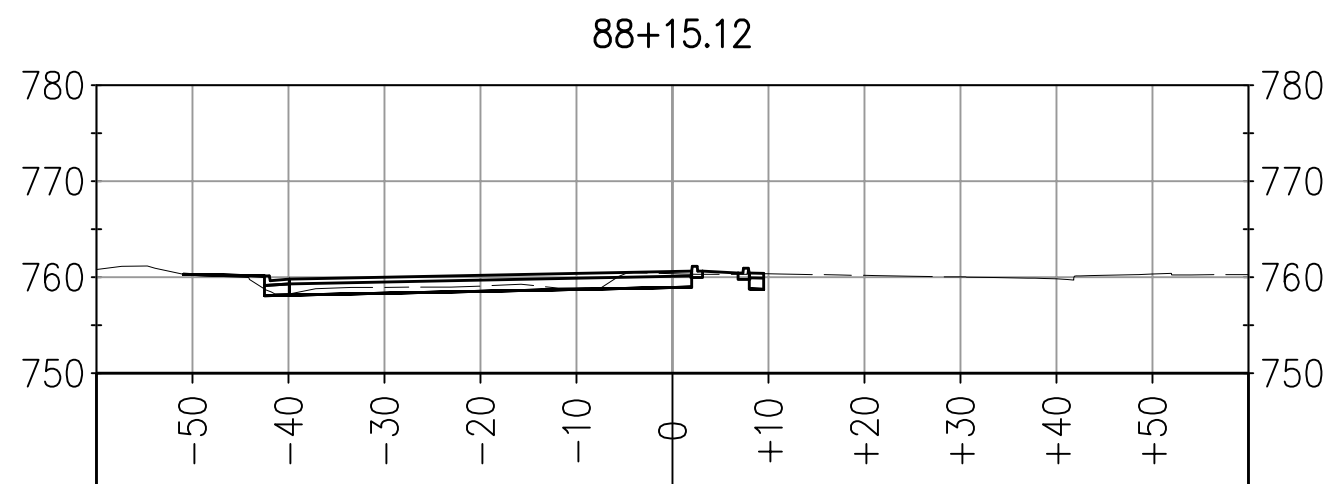
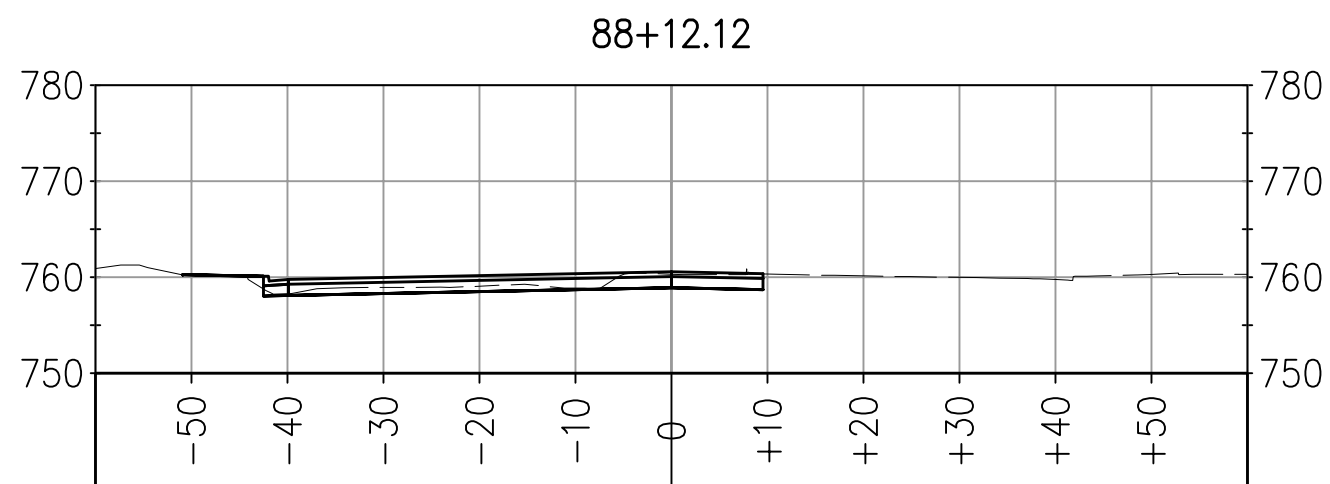
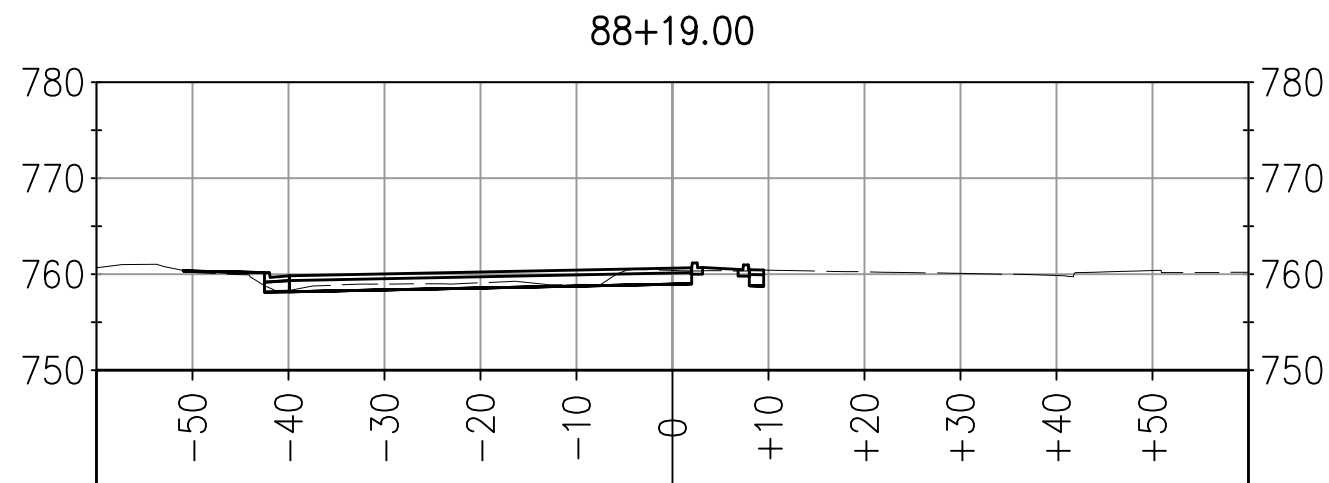
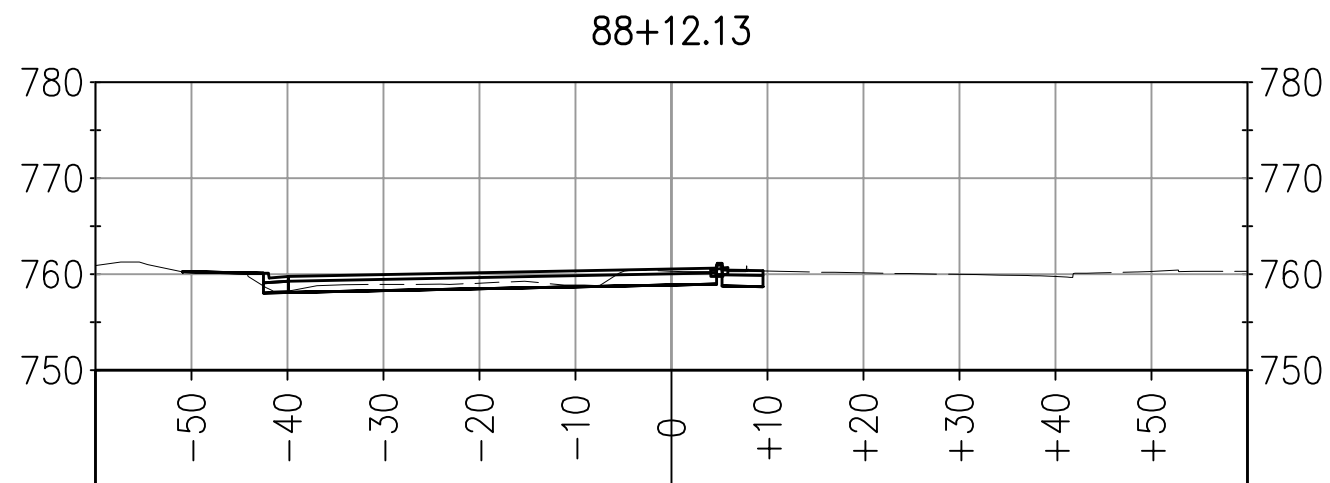

ALIGNMENT: SVP-E
 7-20-10
 DA
 SHEET 3 OF 15

NOTE: MODEL DOES NOT INCLUDE THE FOLLOWING:
 AB UNDER MEDIAN CURB
 AB LIMITS OFFSET FROM SAWCUT
 FINISHED GRADE BETWEEN MEDIAN CURBS

SILVA VALLEY PARKWAY WIDENING SOUTH OF ENTRADA DRIVE #72370
 EL DORADO COUNTY DEPARTMENT OF TRANSPORTATION



PREPARED UNDER THE SUPERVISION OF :

Dwight G. Anderson

REGISTERED CIVIL ENGINEER

7-20-10
 DATE:

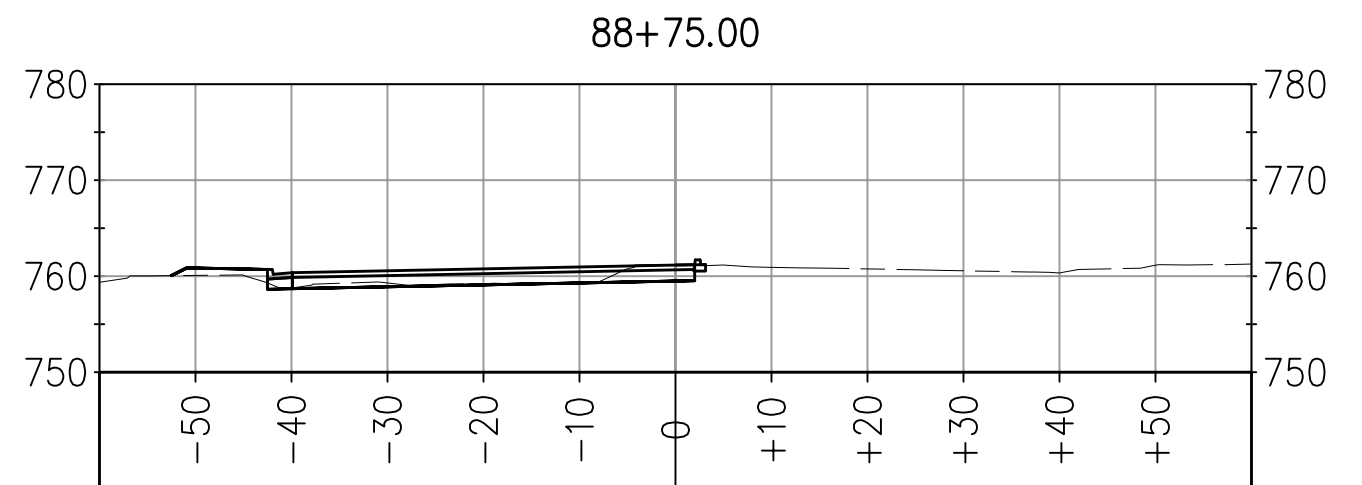
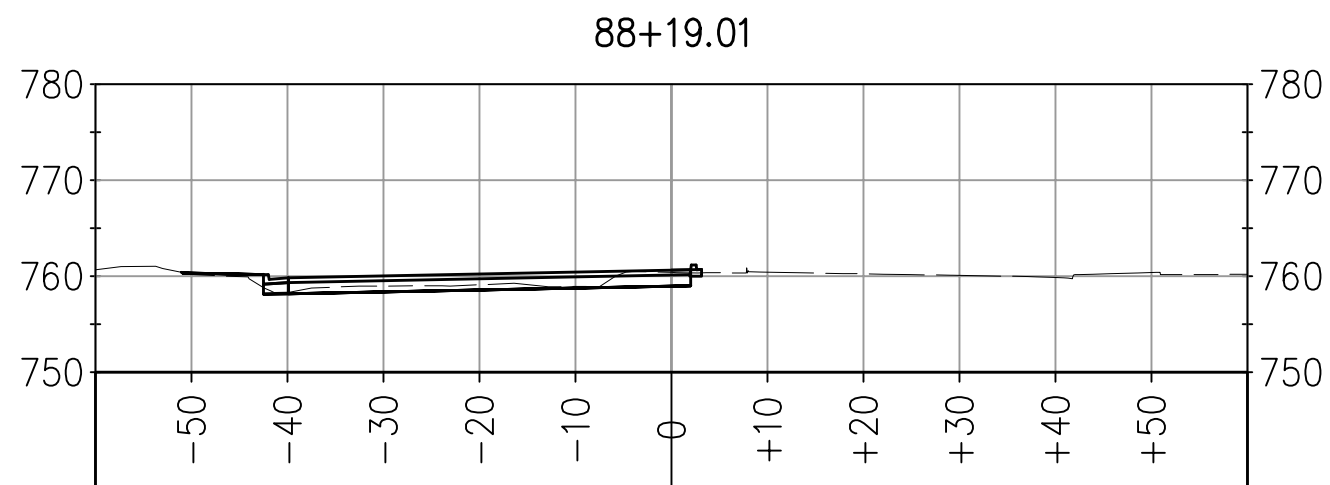
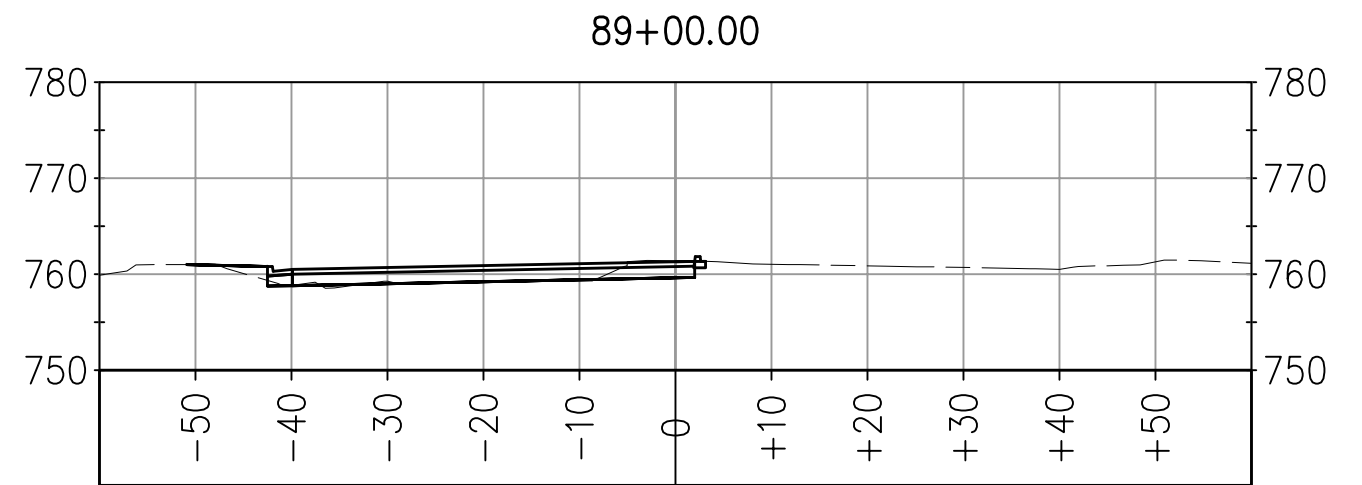
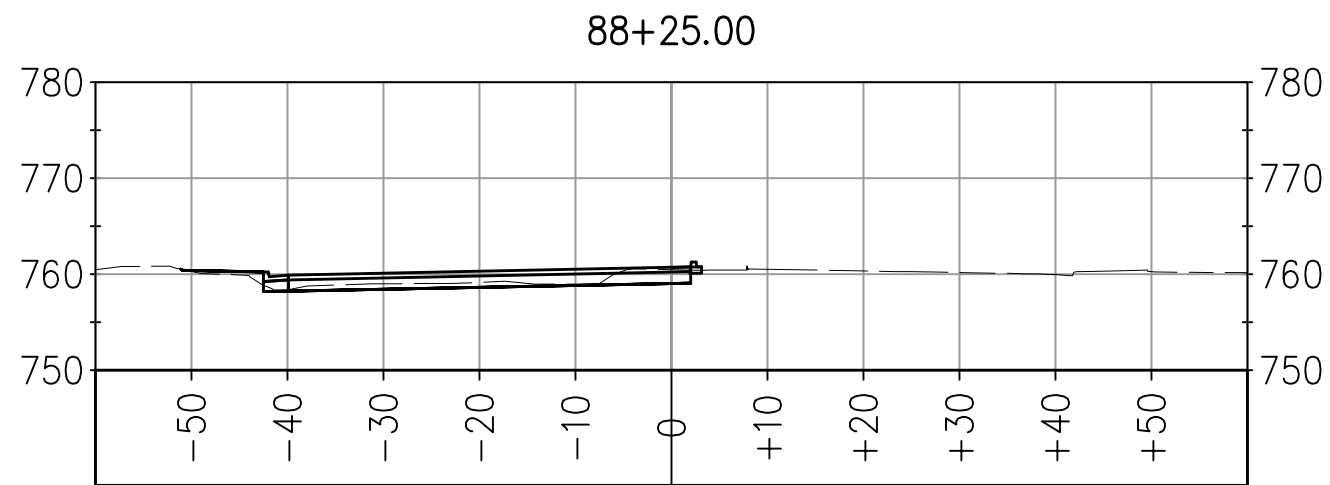
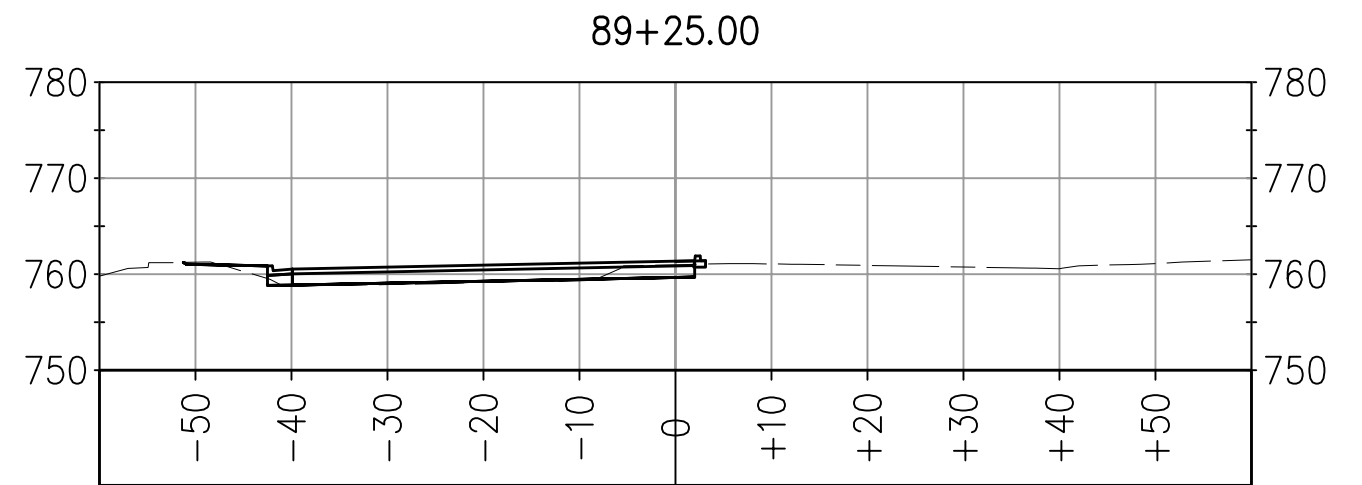
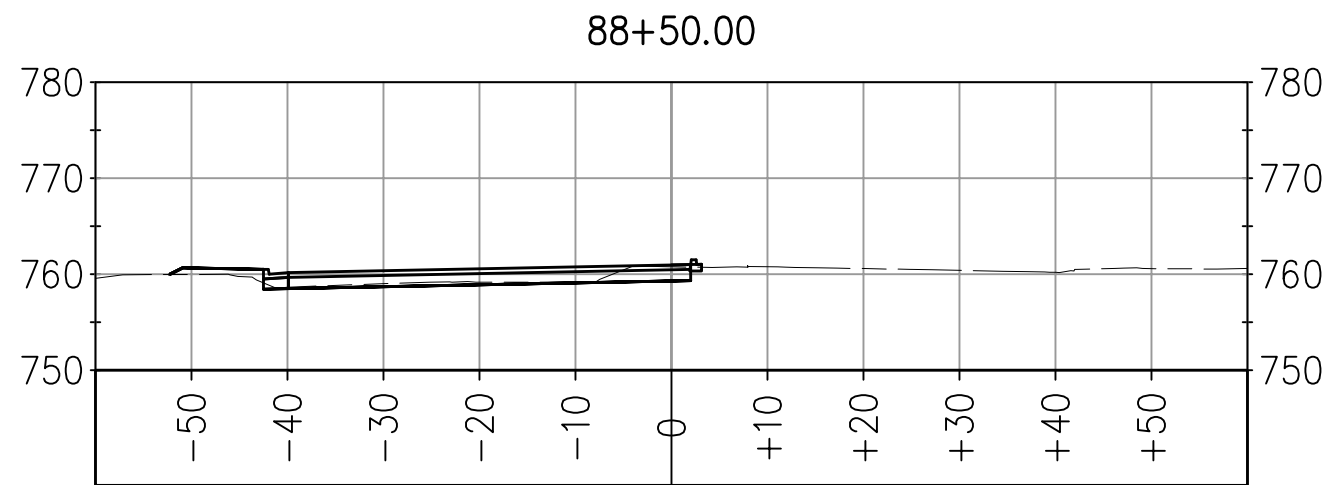

ALIGNMENT: SVP-E
 7-20-10
 DA
 SHEET 4 OF 15

NOTE: MODEL DOES NOT INCLUDE THE FOLLOWING:
 AB UNDER MEDIAN CURB
 AB LIMITS OFFSET FROM SAWCUT
 FINISHED GRADE BETWEEN MEDIAN CURBS

SILVA VALLEY PARKWAY WIDENING SOUTH OF ENTRADA DRIVE #72370
 EL DORADO COUNTY DEPARTMENT OF TRANSPORTATION

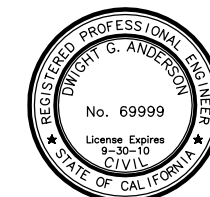

PREPARED UNDER THE SUPERVISION OF:
Dwight G. Anderson
 REGISTERED CIVIL ENGINEER
 DATE: 7-20-10

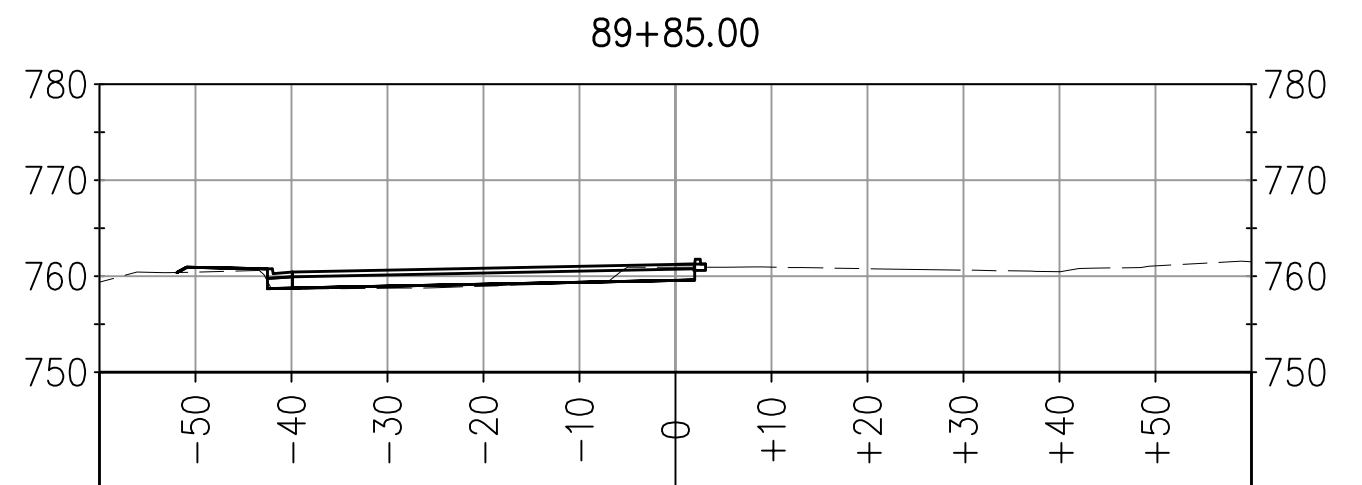
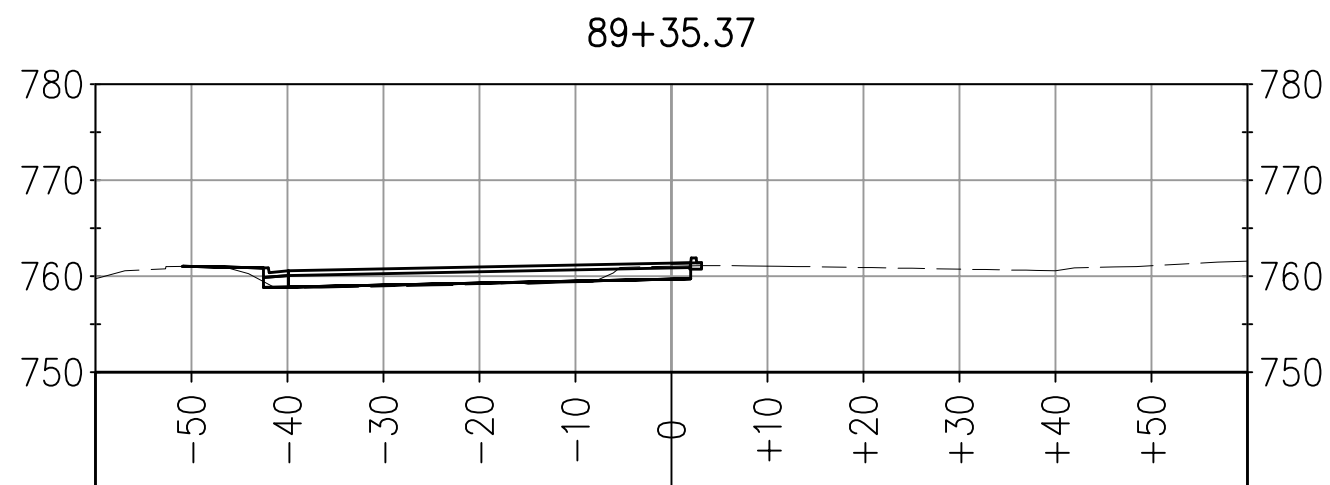
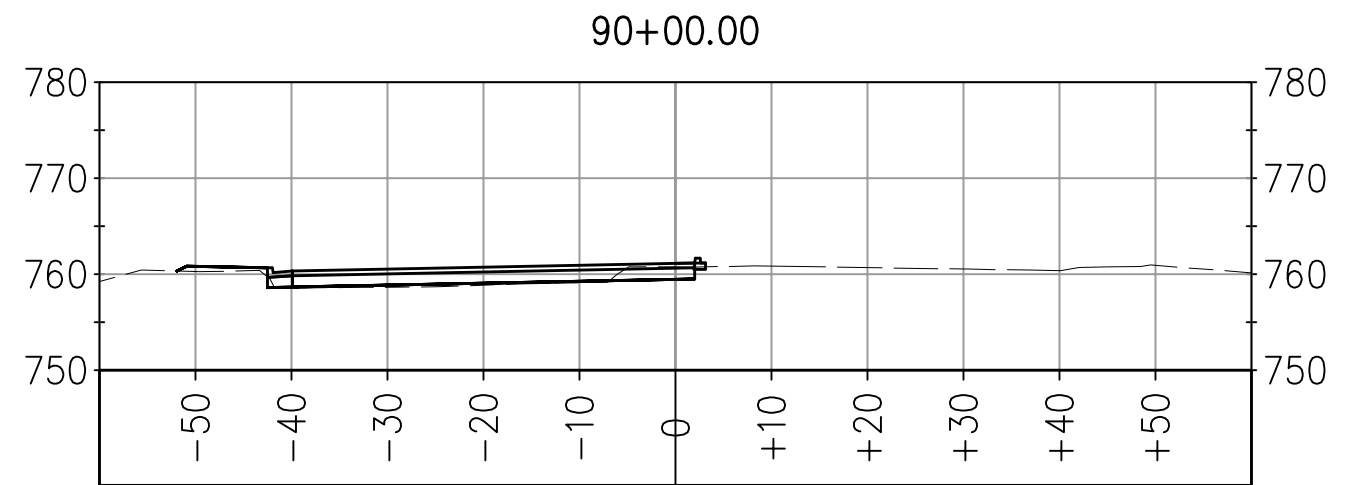
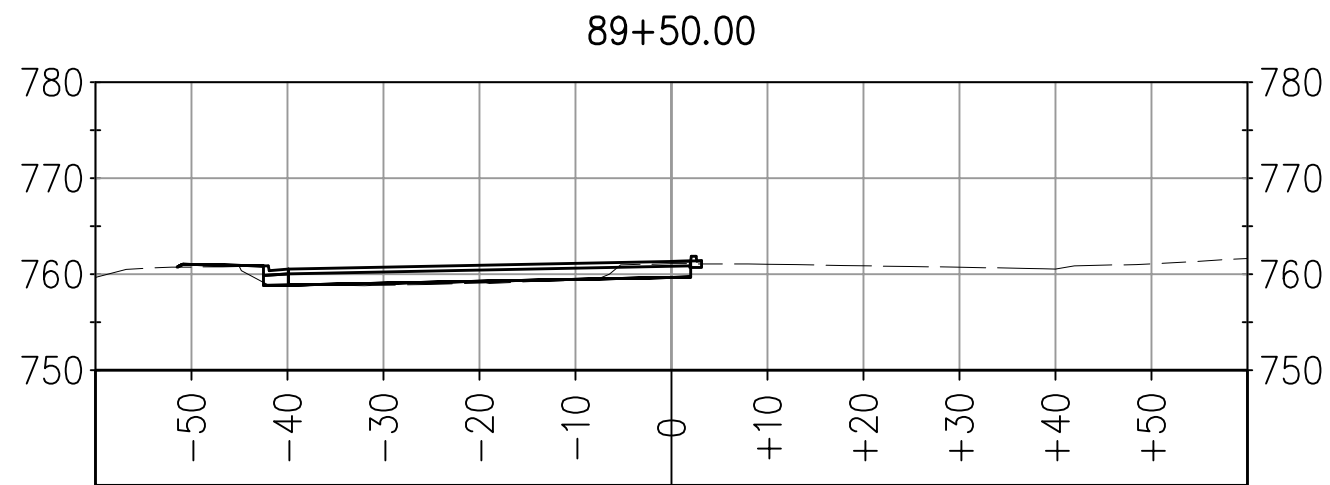
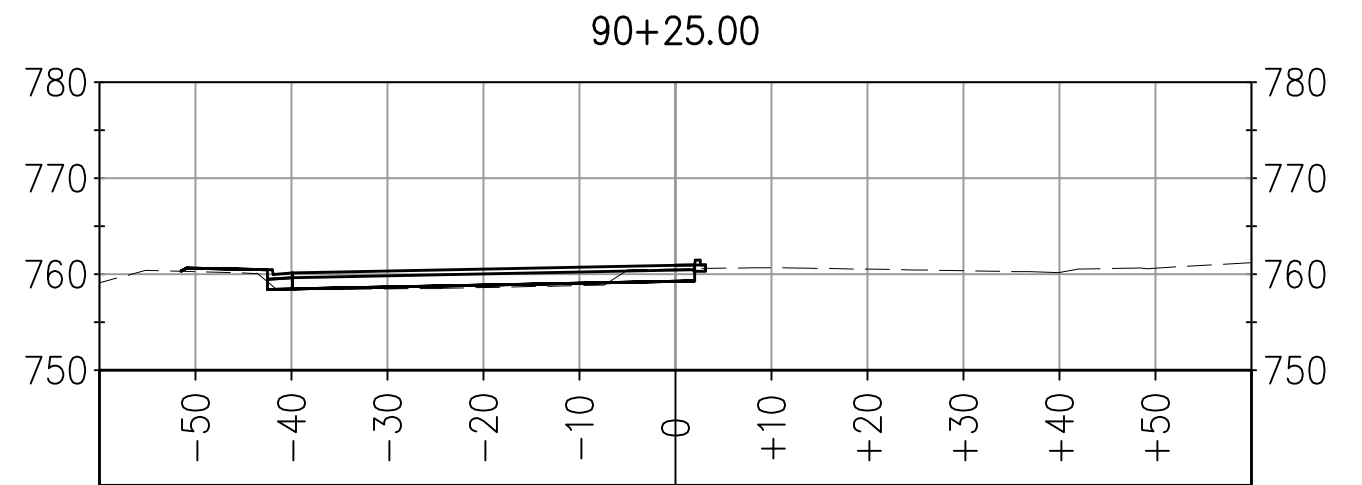
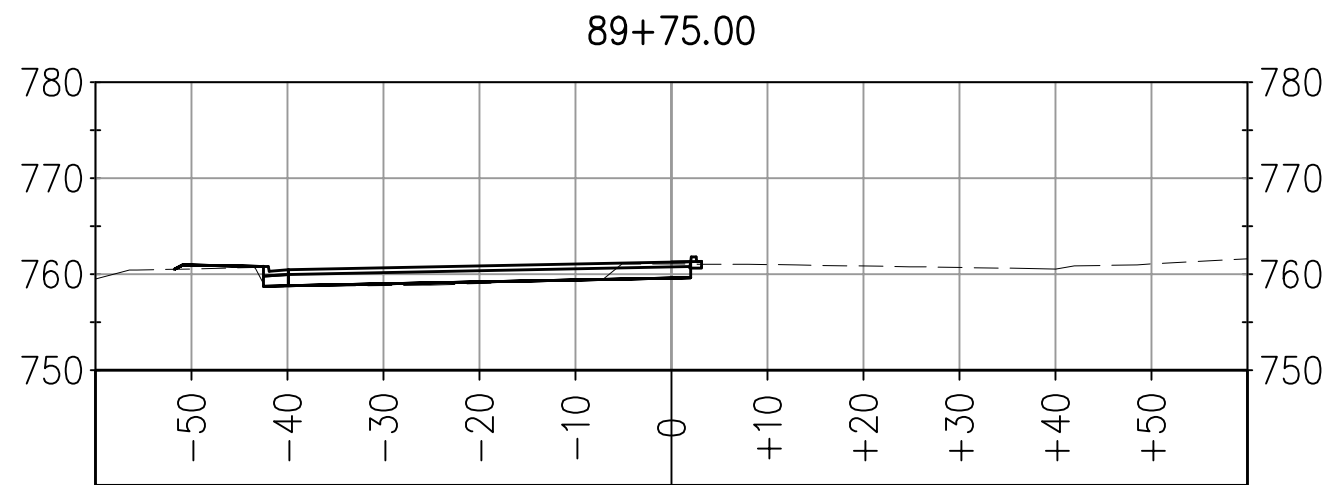

ALIGNMENT: SVP-E
 7-20-10
 DA
 SHEET 5 OF 15

NOTE: MODEL DOES NOT INCLUDE THE FOLLOWING:
 AB UNDER MEDIAN CURB
 AB LIMITS OFFSET FROM SAWCUT
 FINISHED GRADE BETWEEN MEDIAN CURBS

SILVA VALLEY PARKWAY WIDENING SOUTH OF ENTRADA DRIVE #72370
 EL DORADO COUNTY DEPARTMENT OF TRANSPORTATION

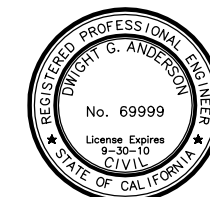

PREPARED UNDER THE SUPERVISION OF:
Dwight G. Anderson
 REGISTERED CIVIL ENGINEER
 DATE: 7-20-10

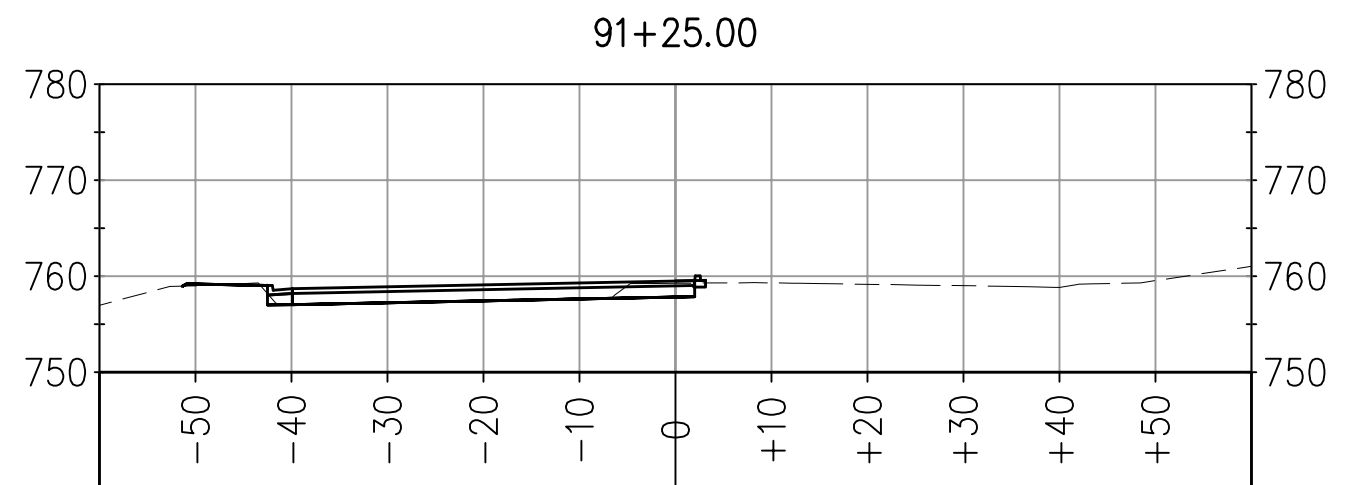
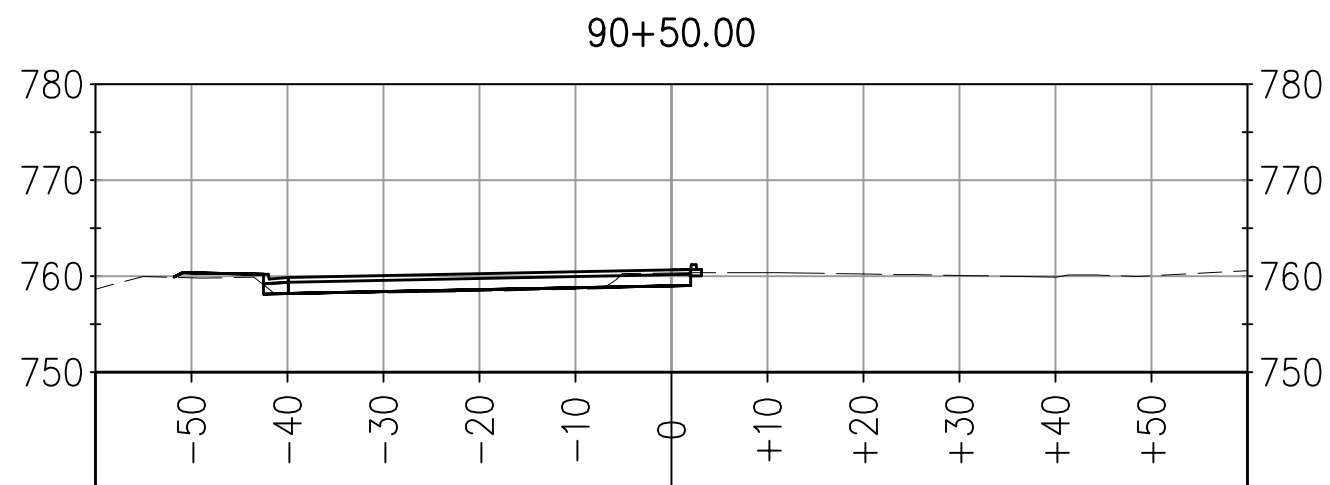
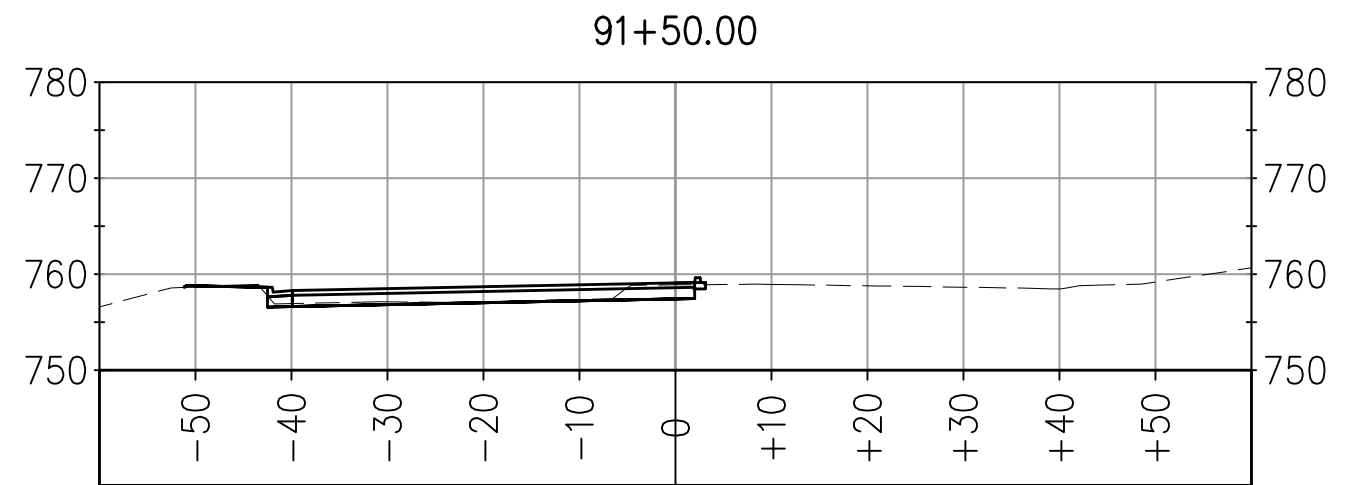
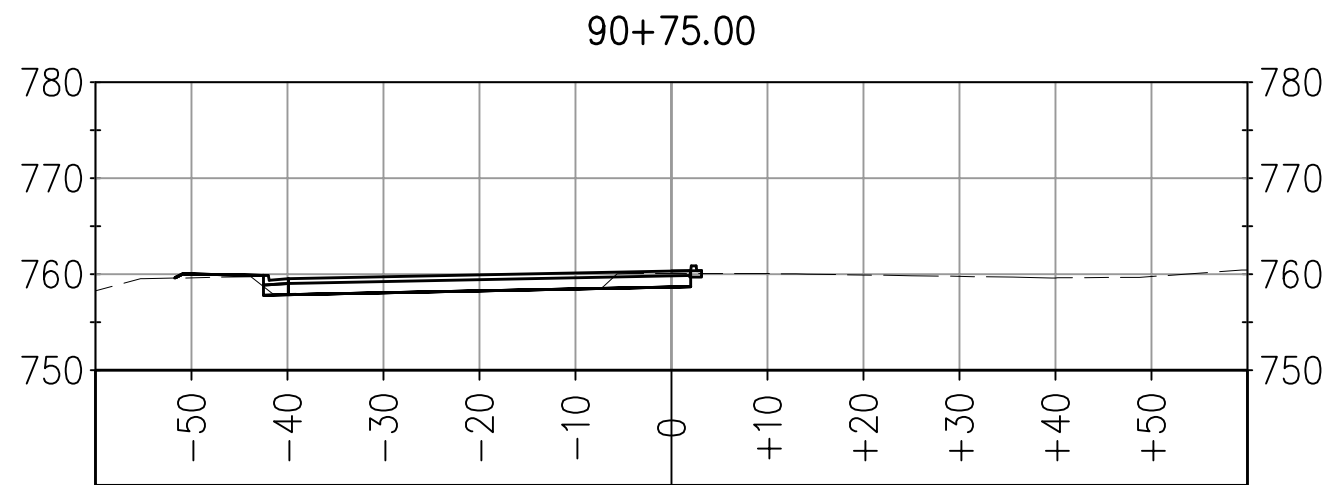
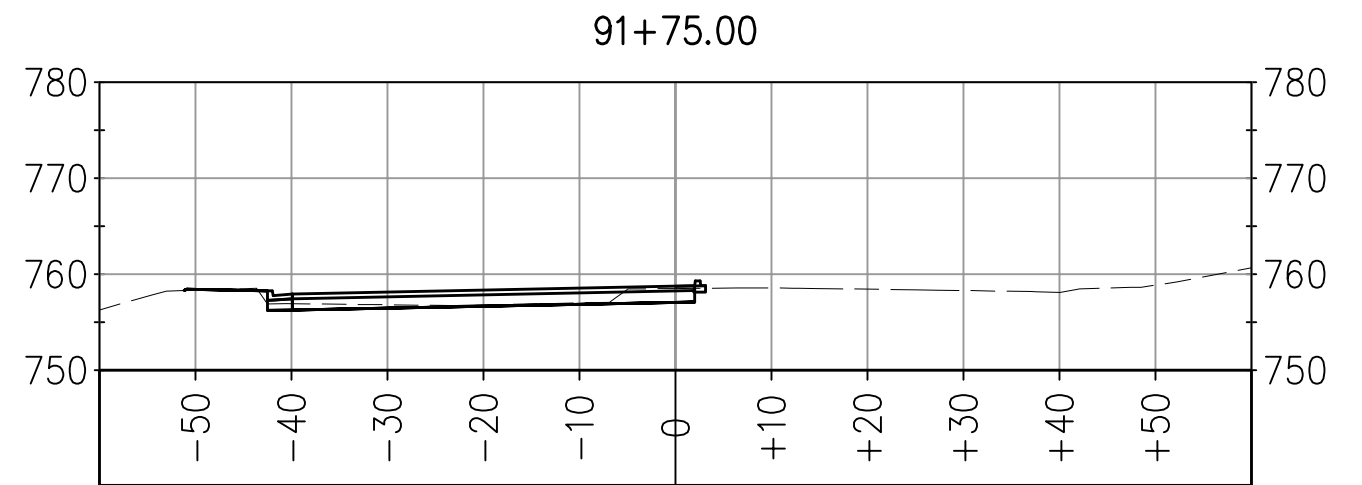
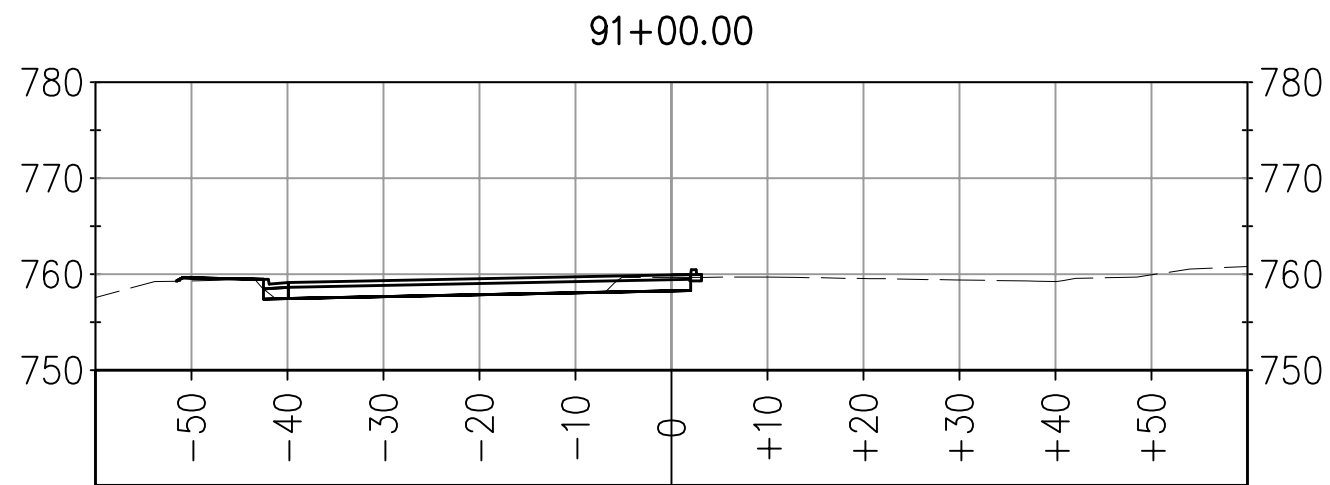

ALIGNMENT: SVP-E
 7-20-10
 DA
 SHEET 6 OF 15

NOTE: MODEL DOES NOT INCLUDE THE FOLLOWING:
 AB UNDER MEDIAN CURB
 AB LIMITS OFFSET FROM SAWCUT
 FINISHED GRADE BETWEEN MEDIAN CURBS

SILVA VALLEY PARKWAY WIDENING SOUTH OF ENTRADA DRIVE #72370
 EL DORADO COUNTY DEPARTMENT OF TRANSPORTATION

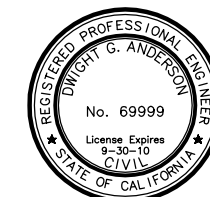

PREPARED UNDER THE SUPERVISION OF:
Dwight G. Anderson
 REGISTERED CIVIL ENGINEER
 DATE: 7-20-10

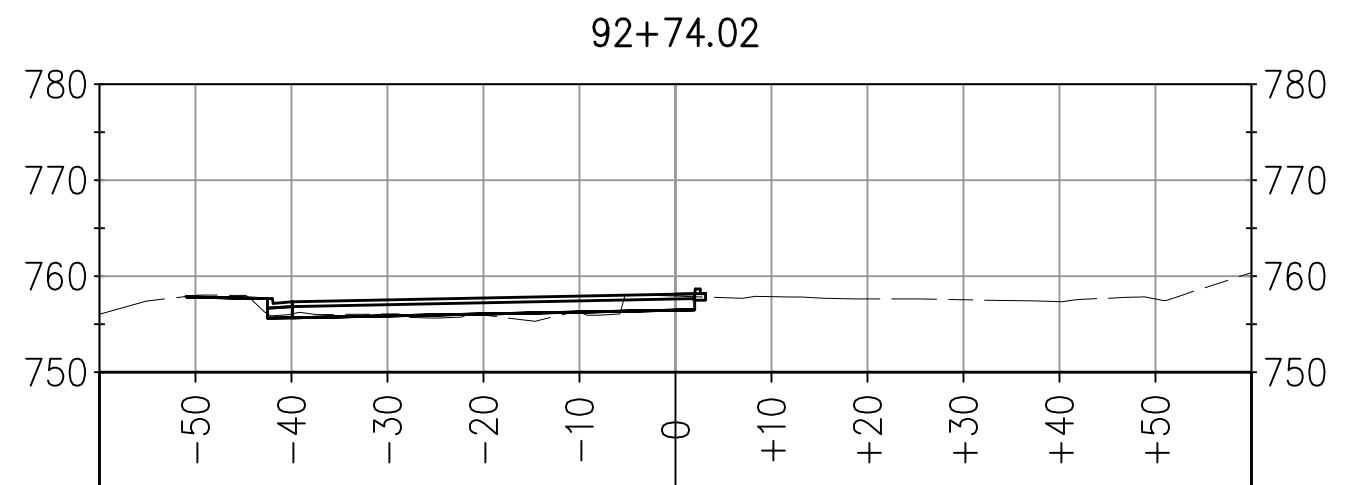
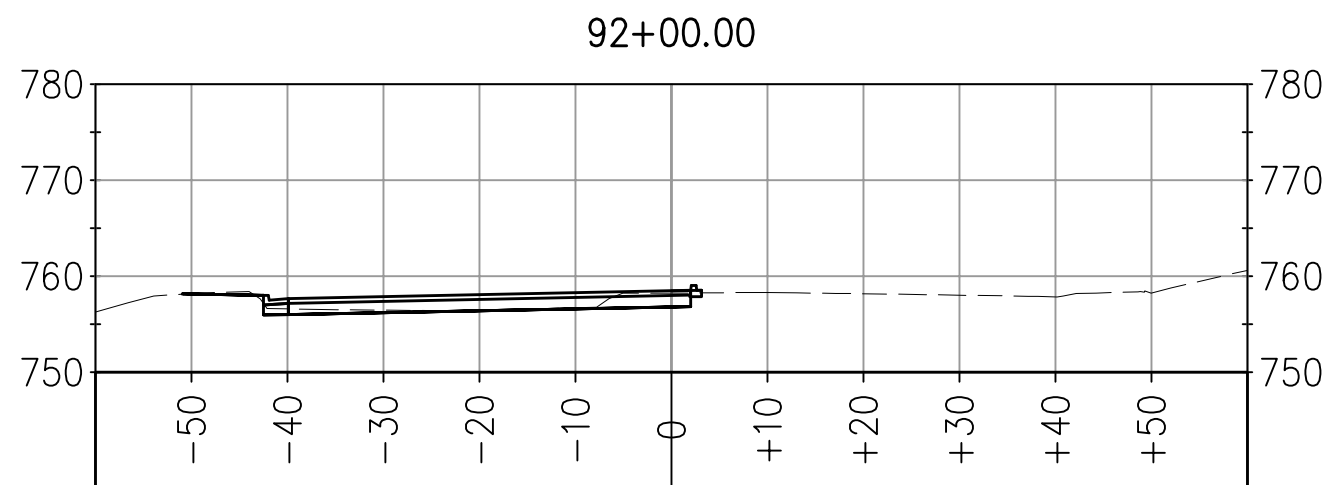
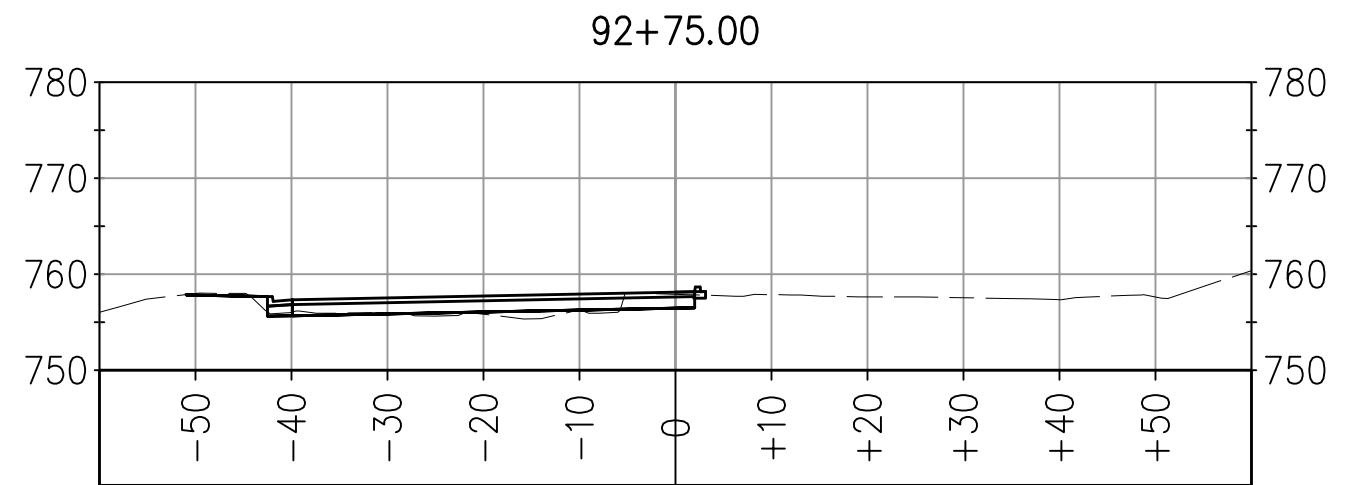
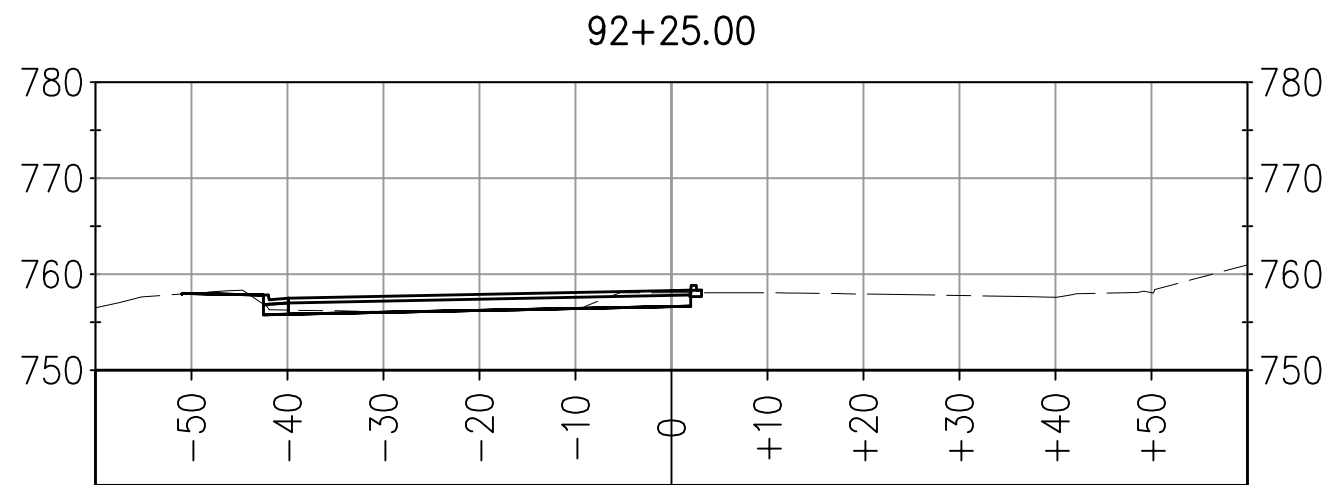
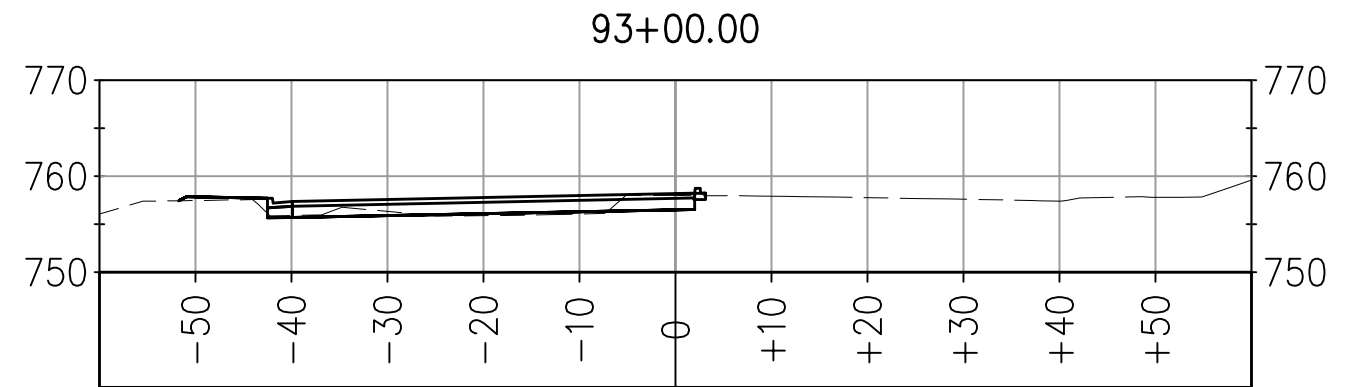
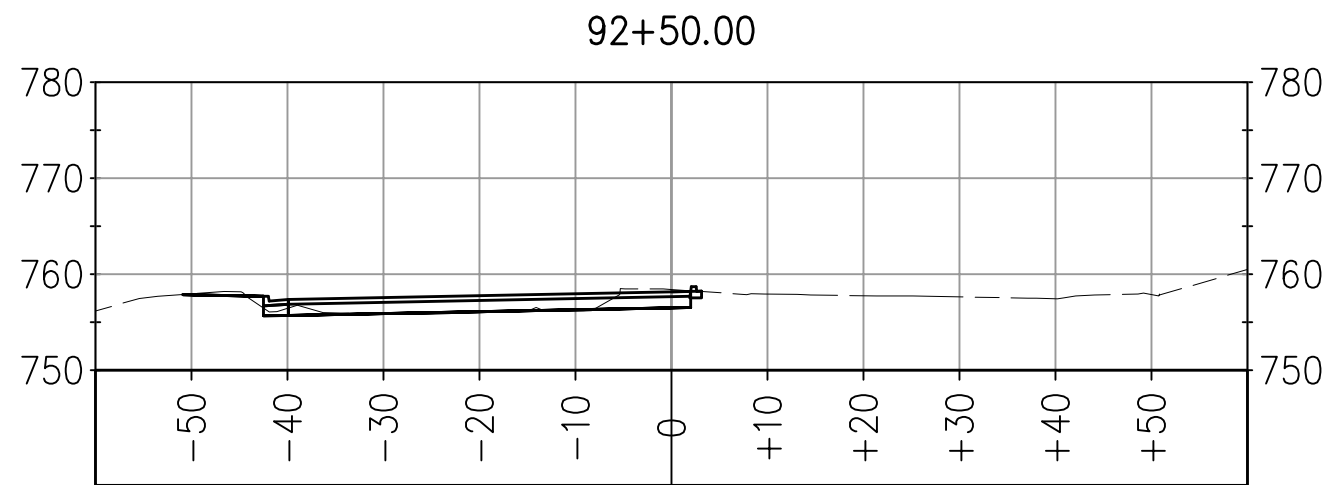

ALIGNMENT: SVP-E
 7-20-10
 DA
 SHEET 7 OF 15

NOTE: MODEL DOES NOT INCLUDE THE FOLLOWING:
 AB UNDER MEDIAN CURB
 AB LIMITS OFFSET FROM SAWCUT
 FINISHED GRADE BETWEEN MEDIAN CURBS

SILVA VALLEY PARKWAY WIDENING SOUTH OF ENTRADA DRIVE #72370
 EL DORADO COUNTY DEPARTMENT OF TRANSPORTATION

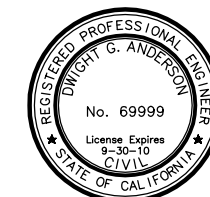

PREPARED UNDER THE SUPERVISION OF :

Dwight G. Anderson
 REGISTERED CIVIL ENGINEER
 DATE: 7-20-10

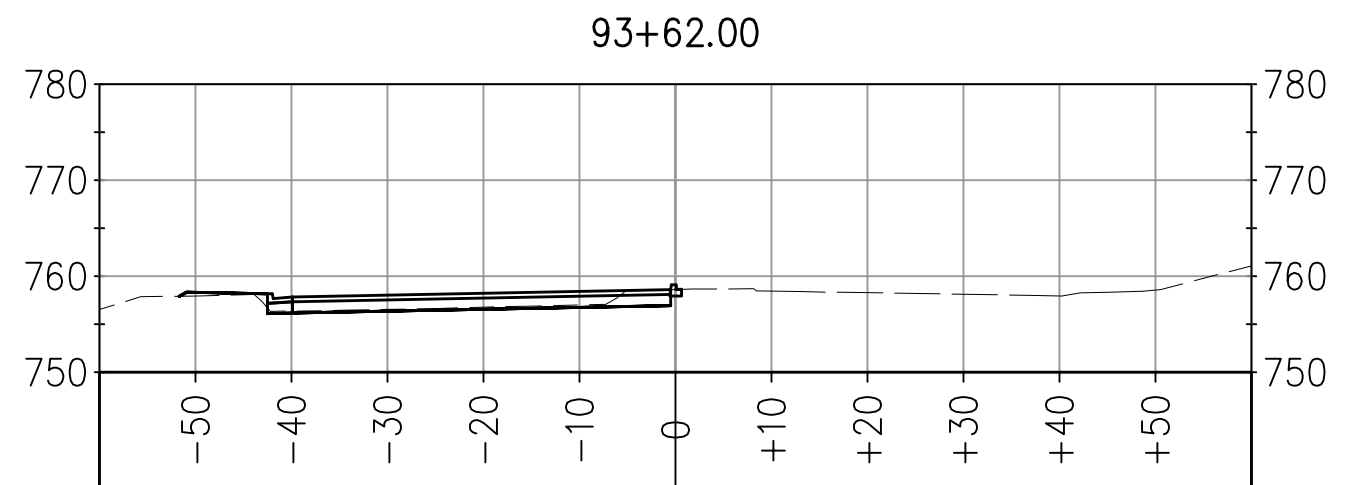
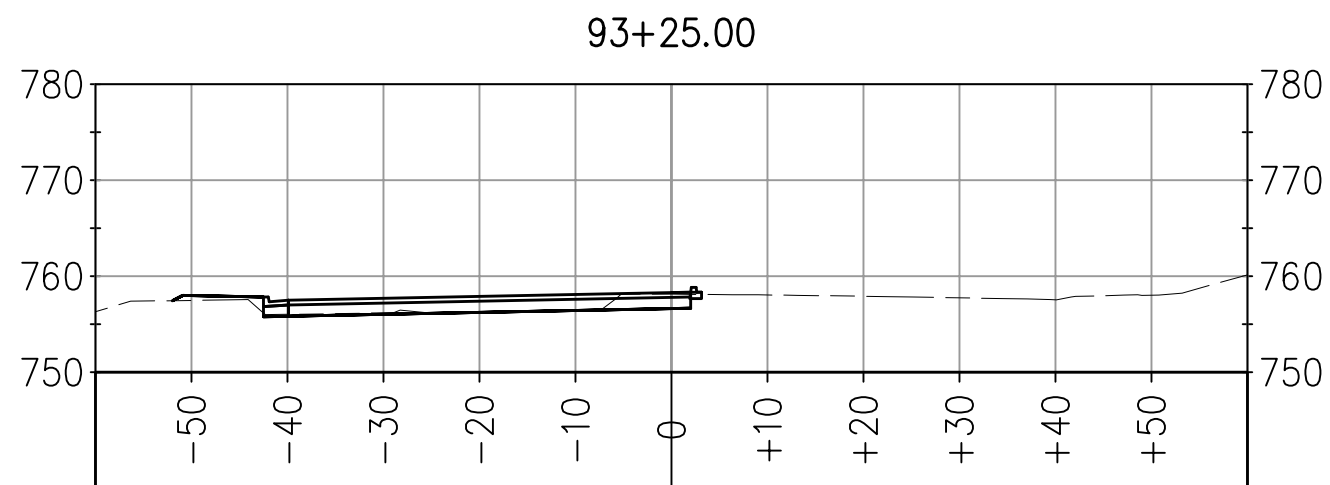
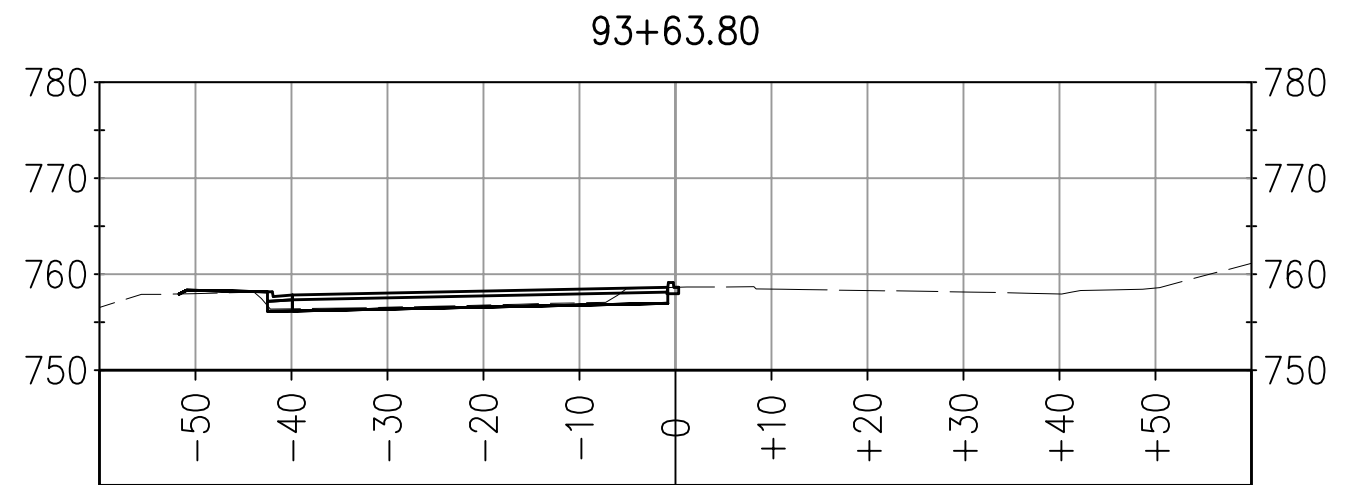
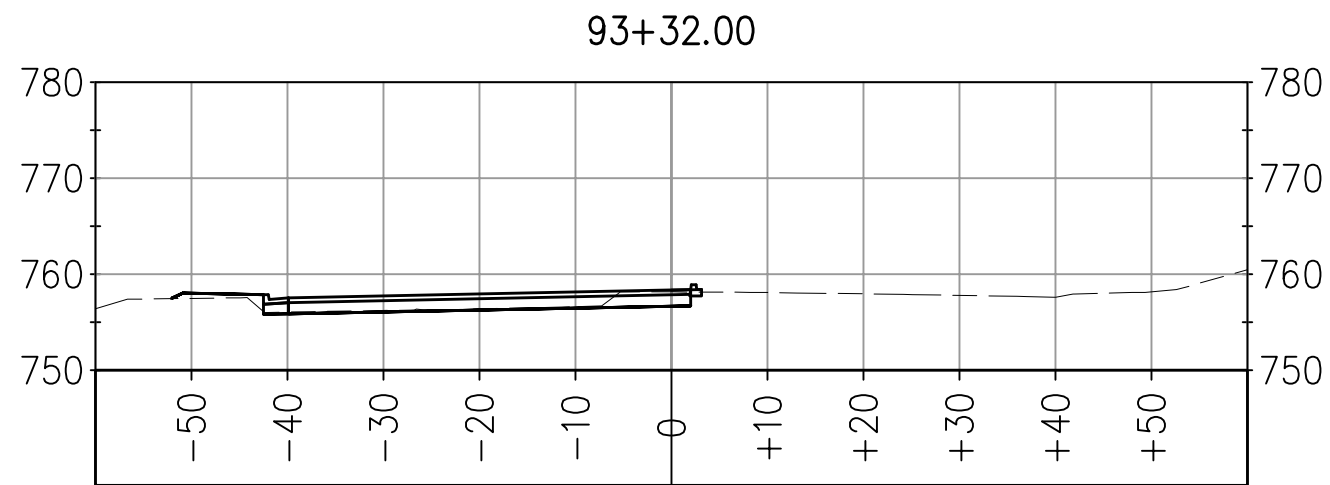
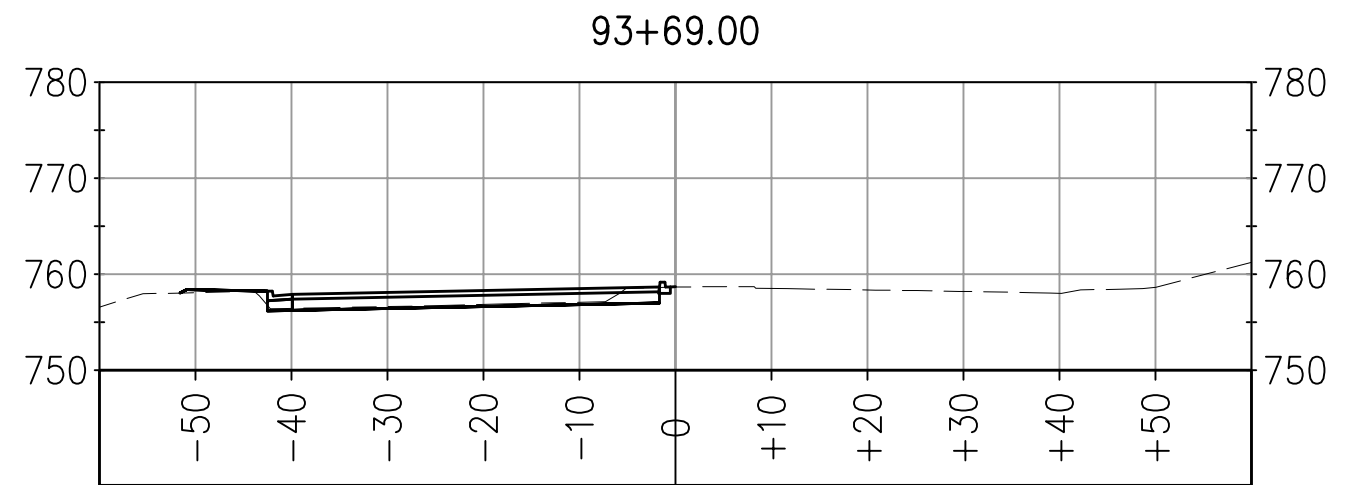
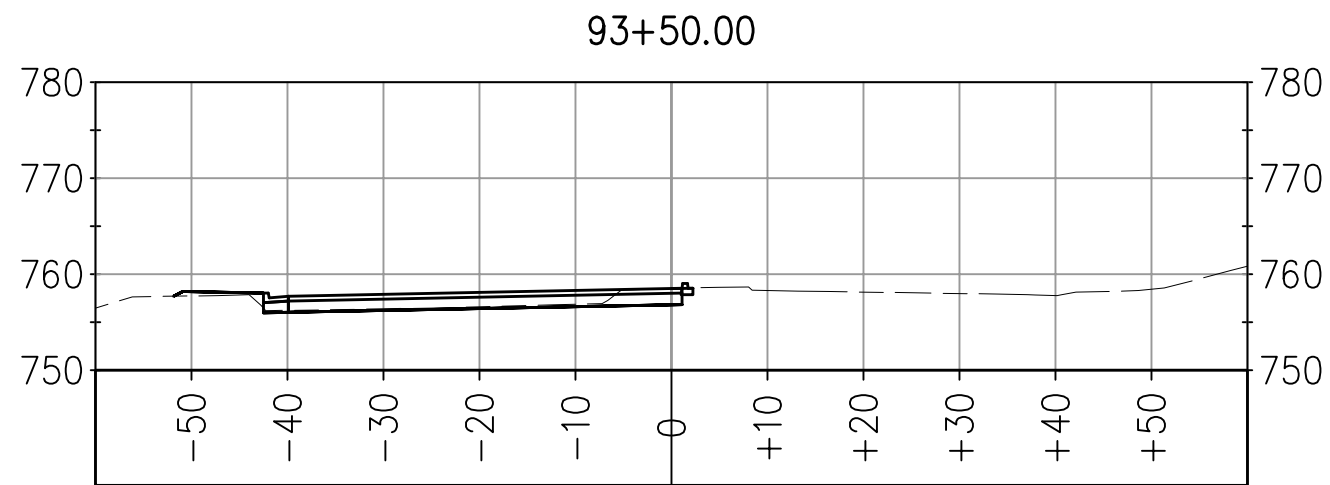

ALIGNMENT: SVP-E
 7-20-10
 DA
 SHEET 8 OF 15

NOTE: MODEL DOES NOT INCLUDE THE FOLLOWING:
 AB UNDER MEDIAN CURB
 AB LIMITS OFFSET FROM SAWCUT
 FINISHED GRADE BETWEEN MEDIAN CURBS

SILVA VALLEY PARKWAY WIDENING SOUTH OF ENTRADA DRIVE #72370
 EL DORADO COUNTY DEPARTMENT OF TRANSPORTATION

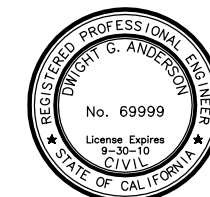

PREPARED UNDER THE SUPERVISION OF:
Dwight G. Anderson
 REGISTERED CIVIL ENGINEER
 DATE: 7-20-10

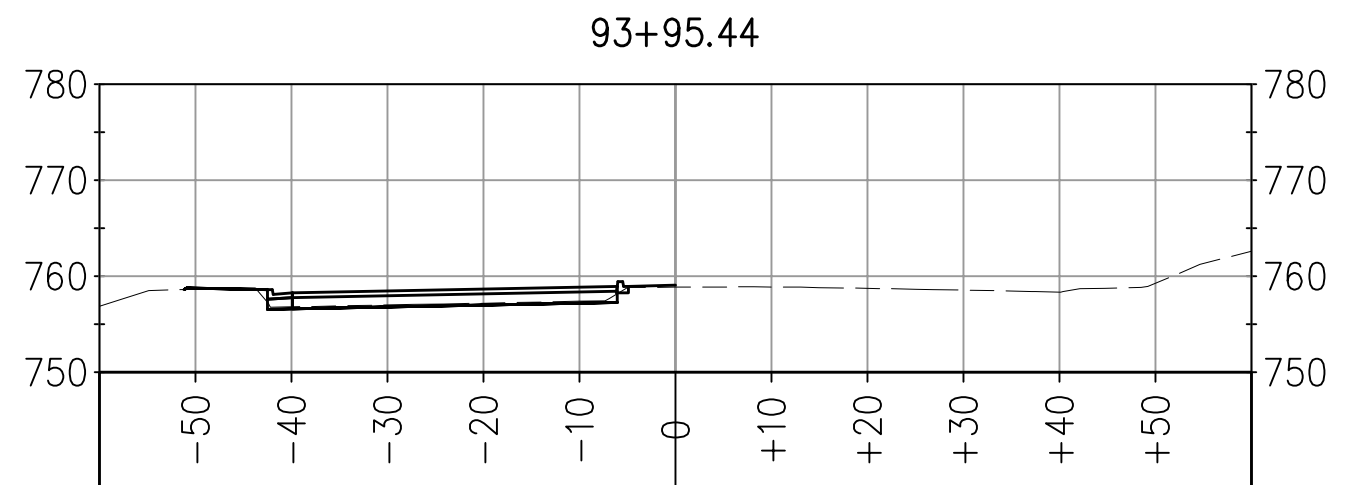
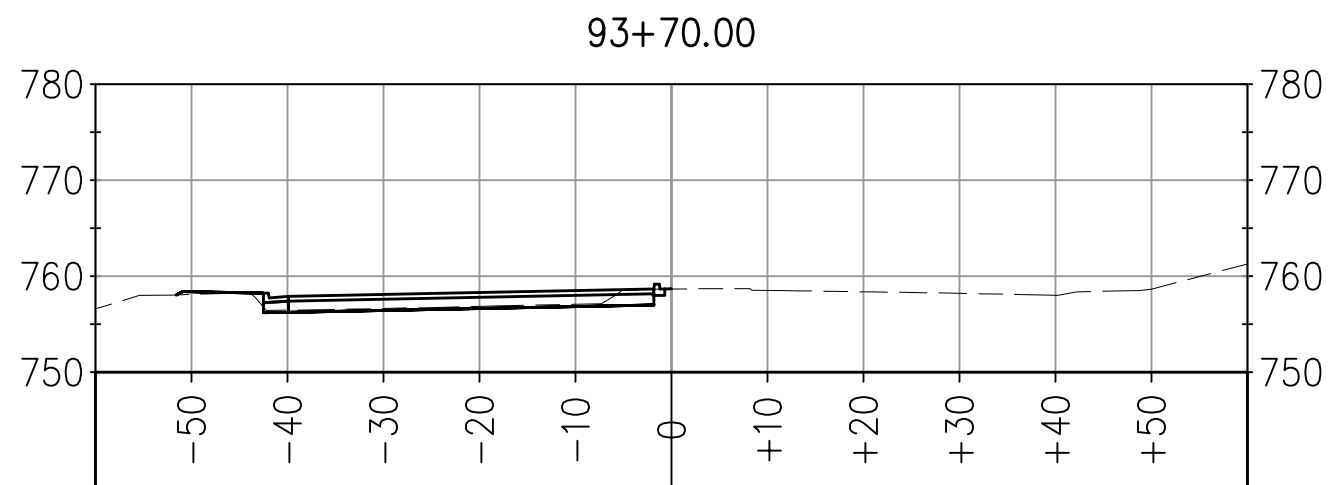
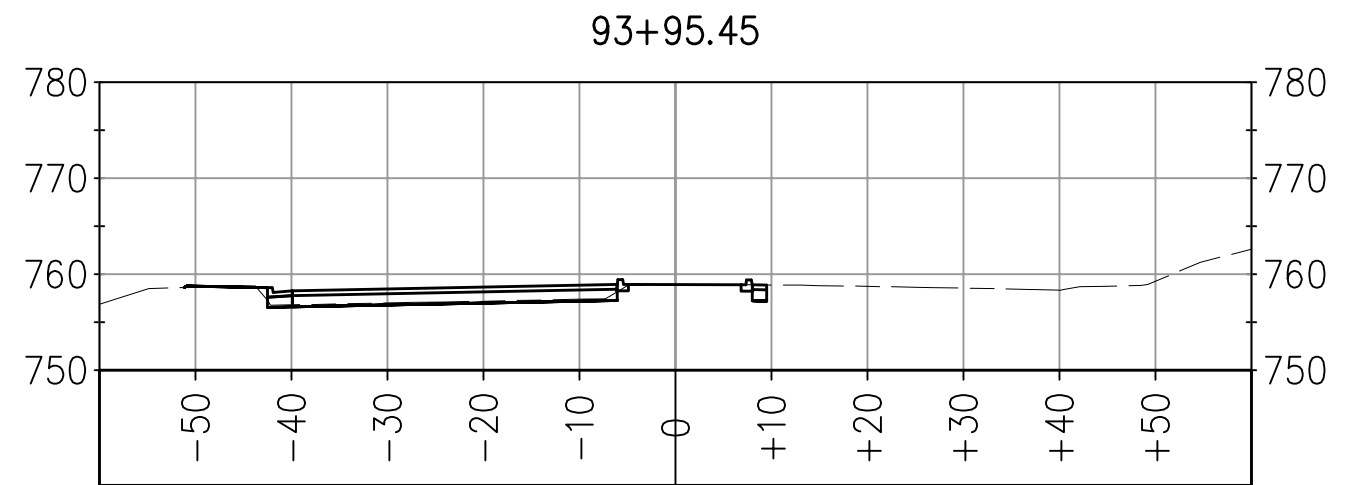
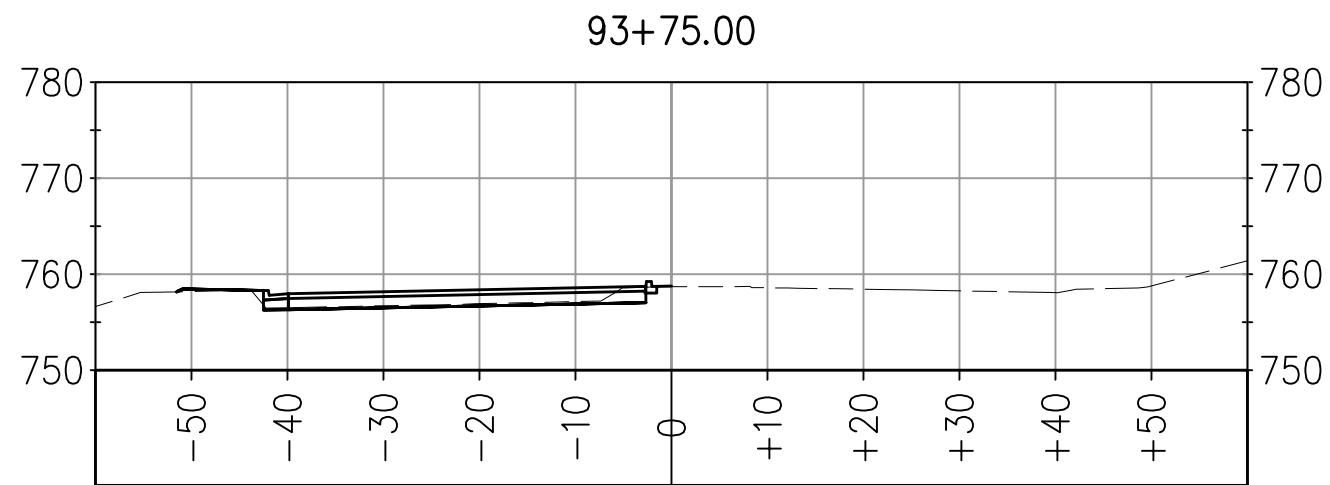
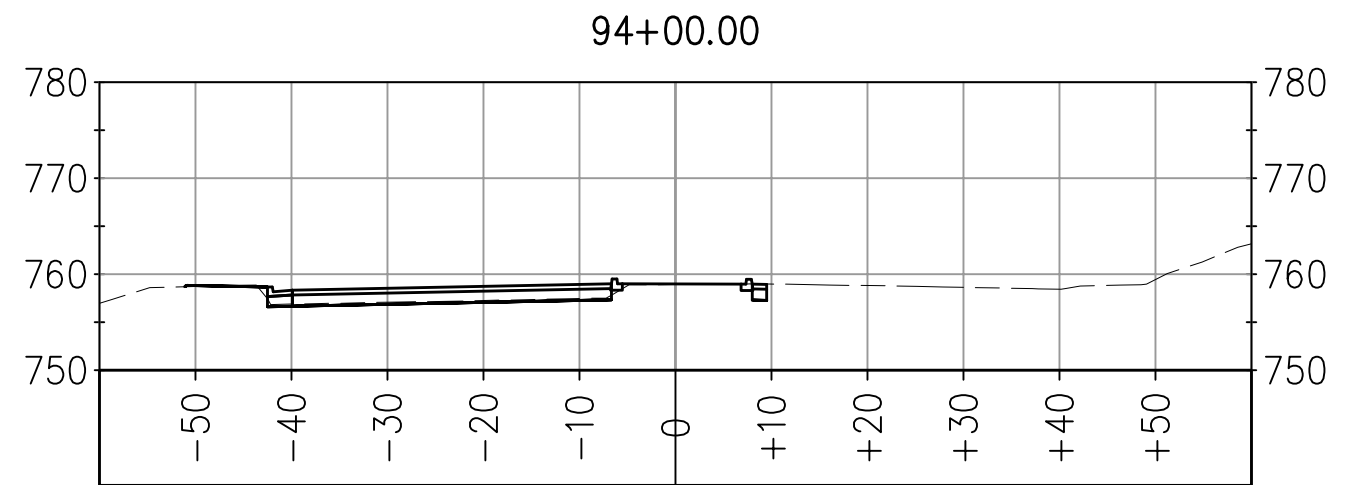
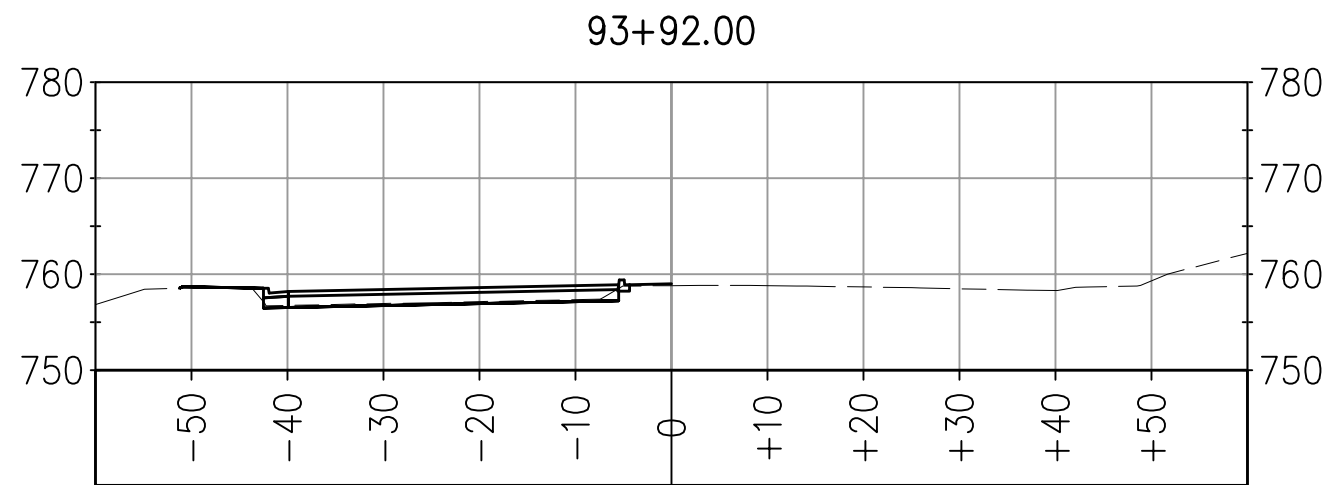

ALIGNMENT: SVP-E
 7-20-10
 DA
 SHEET 9 OF 15

NOTE: MODEL DOES NOT INCLUDE THE FOLLOWING:
 AB UNDER MEDIAN CURB
 AB LIMITS OFFSET FROM SAWCUT
 FINISHED GRADE BETWEEN MEDIAN CURBS

SILVA VALLEY PARKWAY WIDENING SOUTH OF ENTRADA DRIVE #72370
 EL DORADO COUNTY DEPARTMENT OF TRANSPORTATION

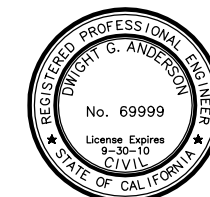

PREPARED UNDER THE SUPERVISION OF:
Dwight G. Anderson
 REGISTERED CIVIL ENGINEER
 DATE: 7-20-10

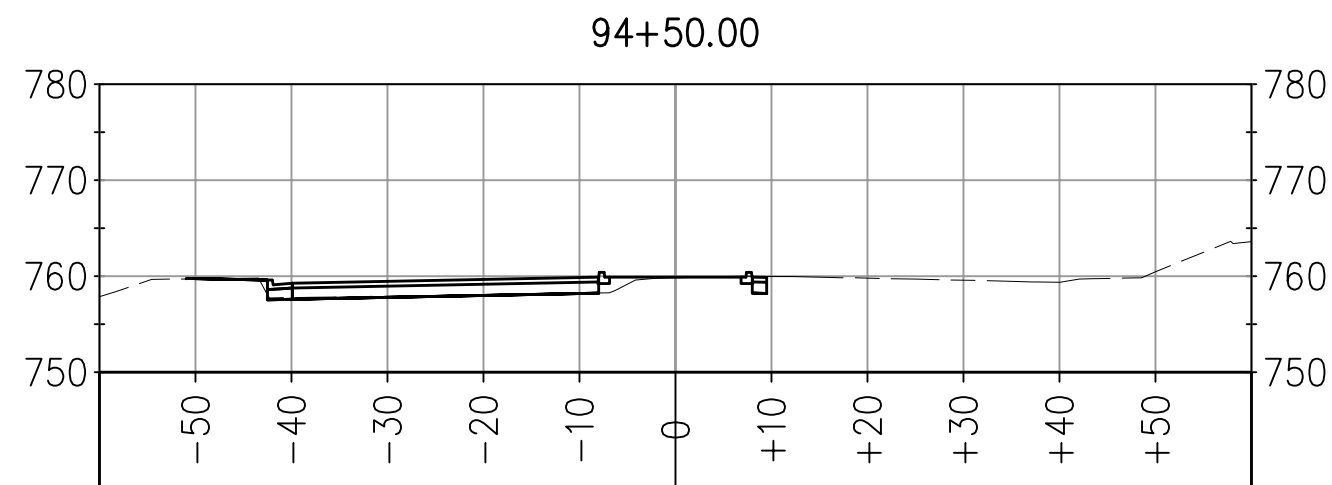
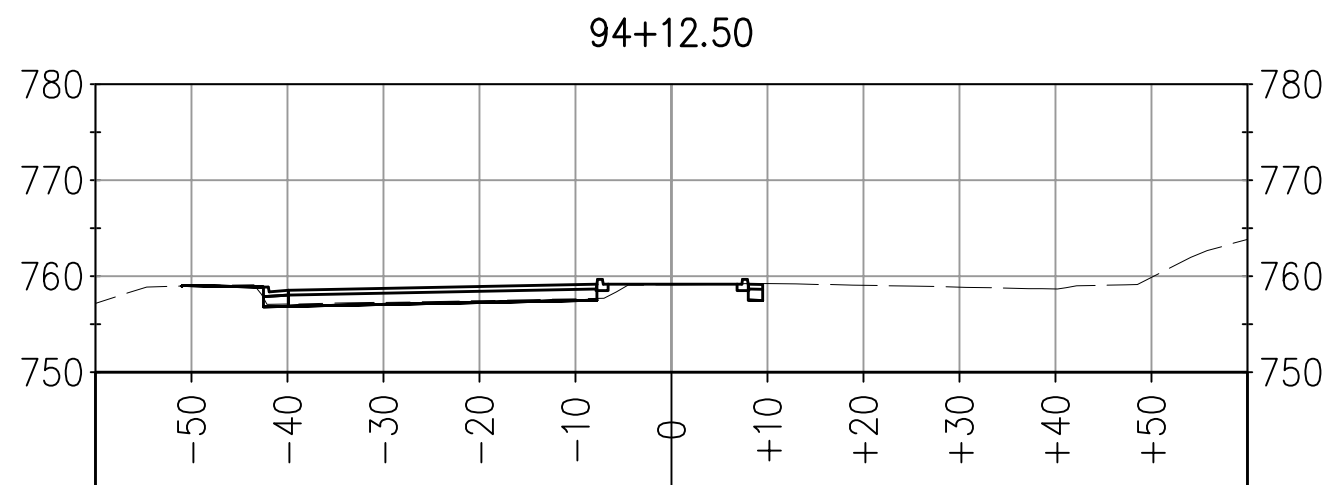
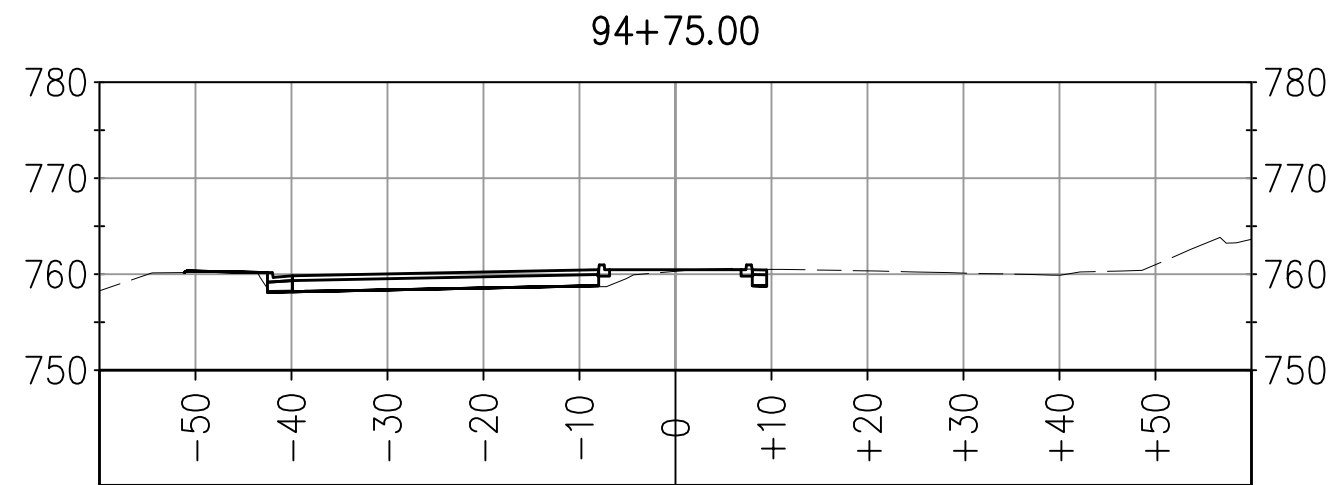
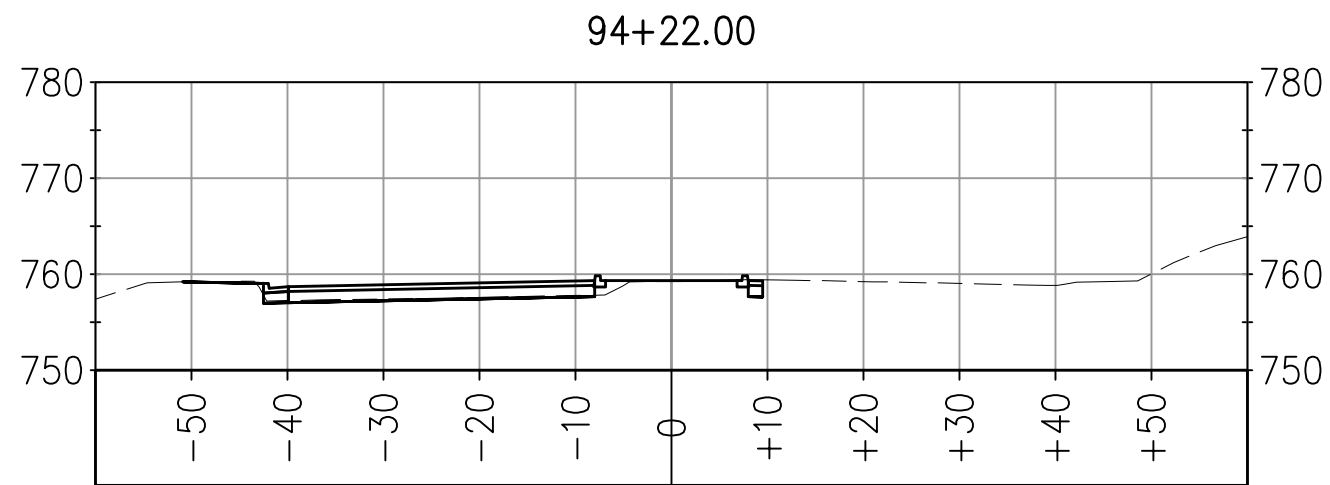
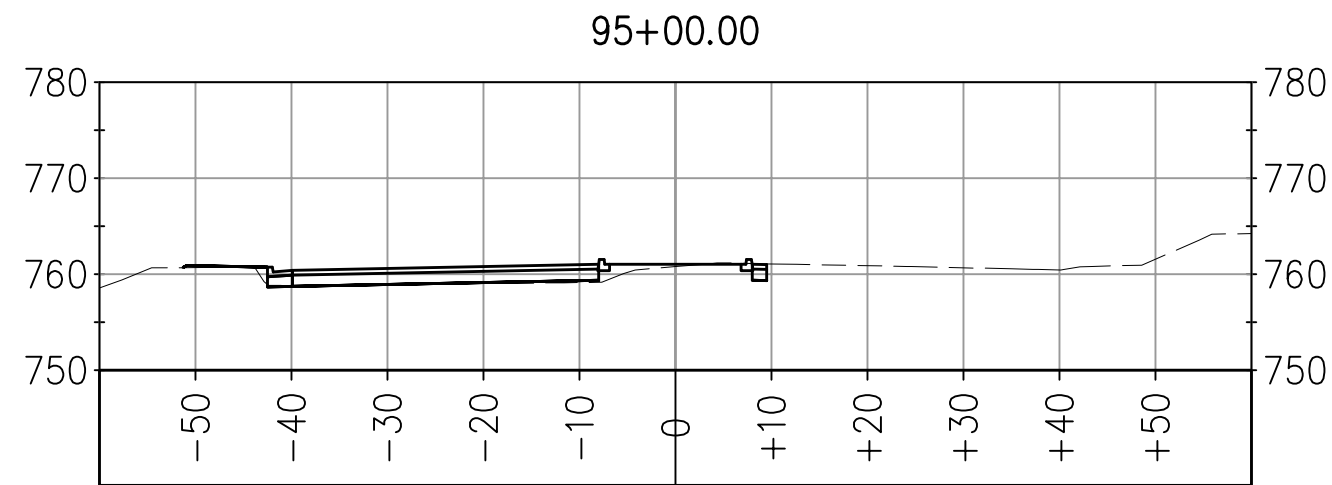
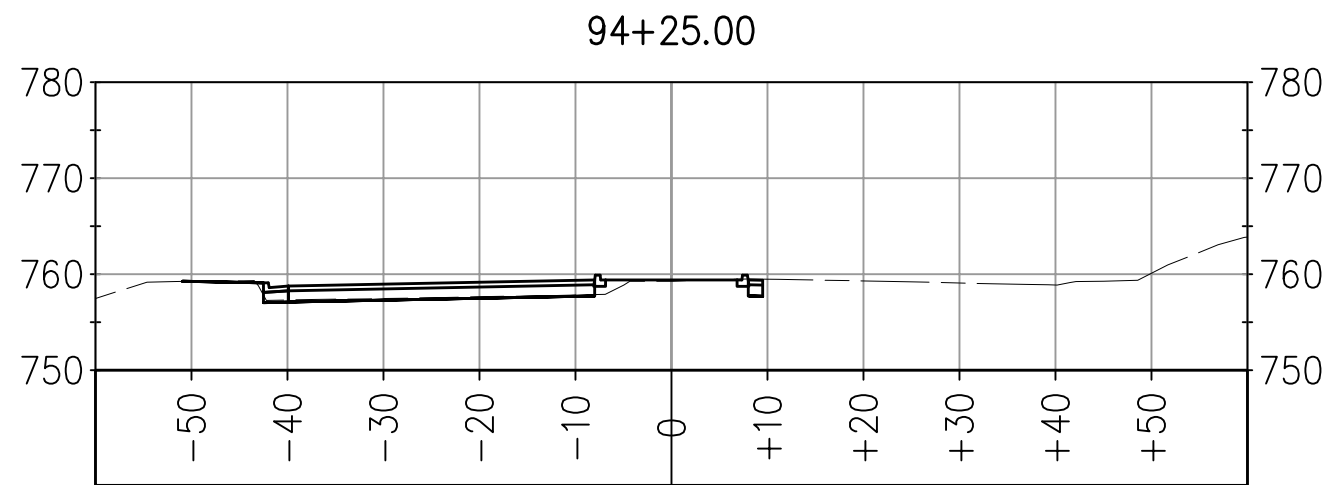

ALIGNMENT: SVP-E
 7-20-10
 DA
 SHEET 10 OF 15

NOTE: MODEL DOES NOT INCLUDE THE FOLLOWING:
 AB UNDER MEDIAN CURB
 AB LIMITS OFFSET FROM SAWCUT
 FINISHED GRADE BETWEEN MEDIAN CURBS

SILVA VALLEY PARKWAY WIDENING SOUTH OF ENTRADA DRIVE #72370
 EL DORADO COUNTY DEPARTMENT OF TRANSPORTATION



PREPARED UNDER THE SUPERVISION OF :

Dwight G. Anderson

REGISTERED CIVIL ENGINEER

7-20-10
 DATE:

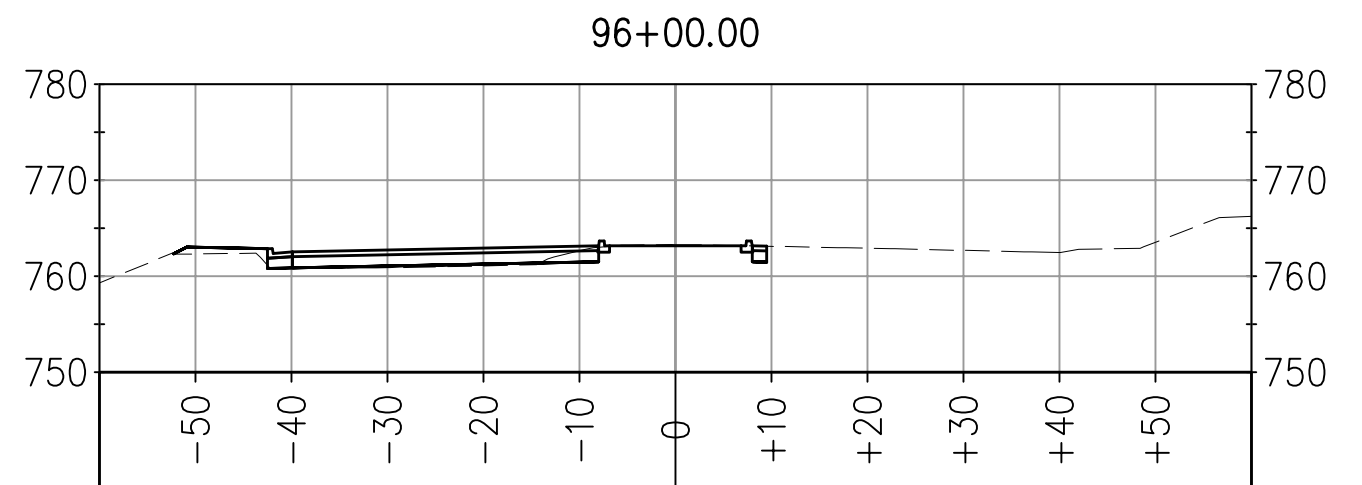
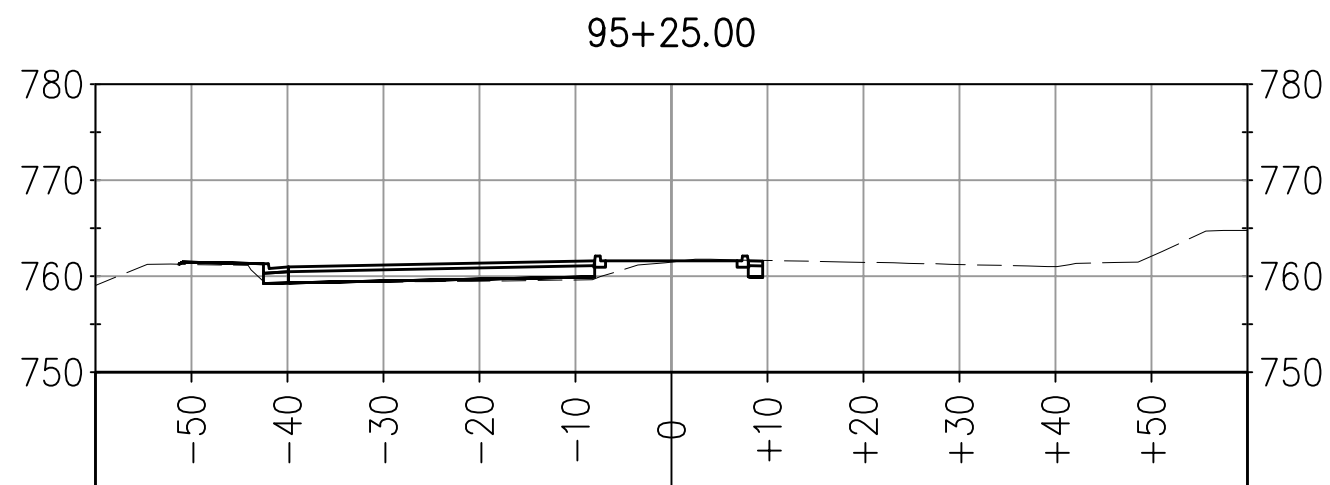
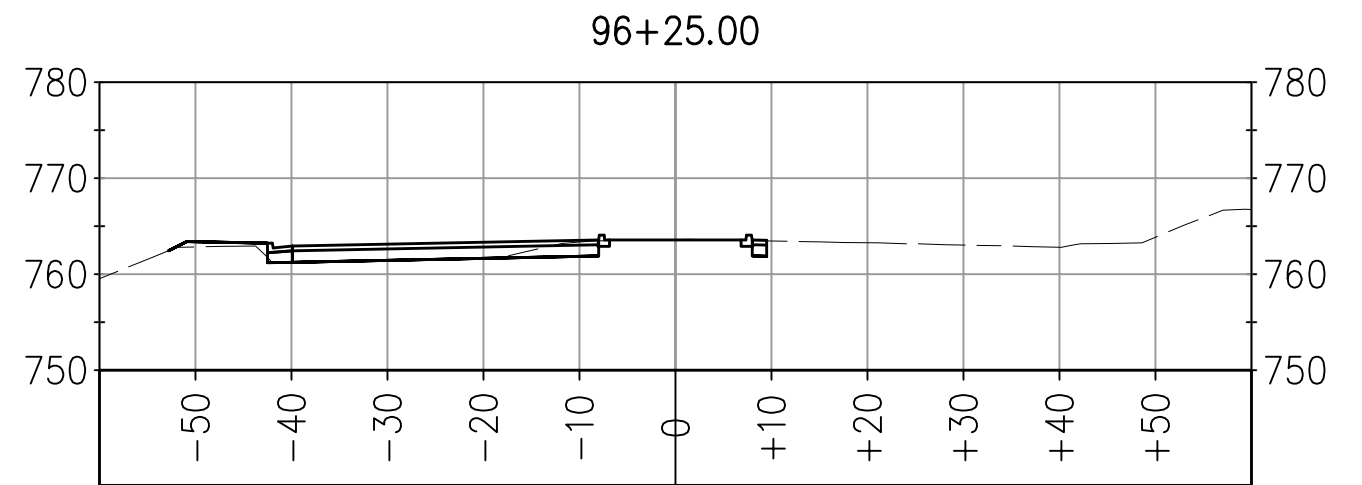
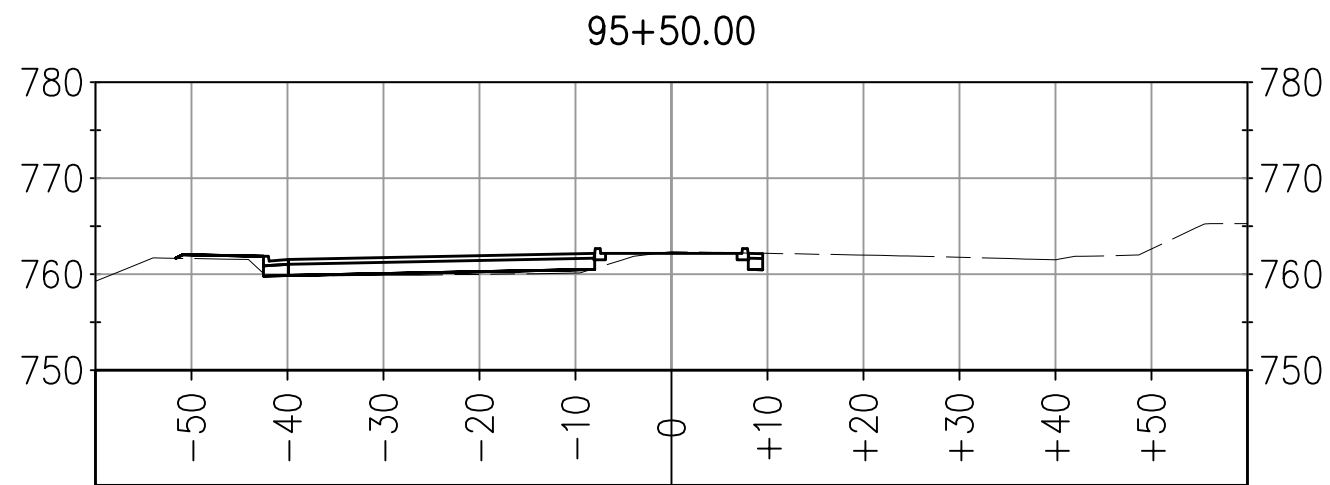
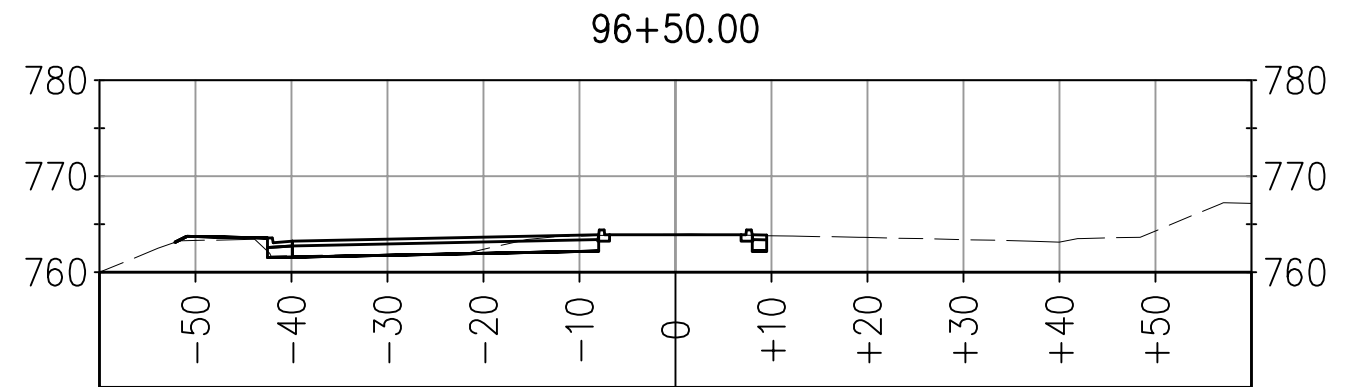
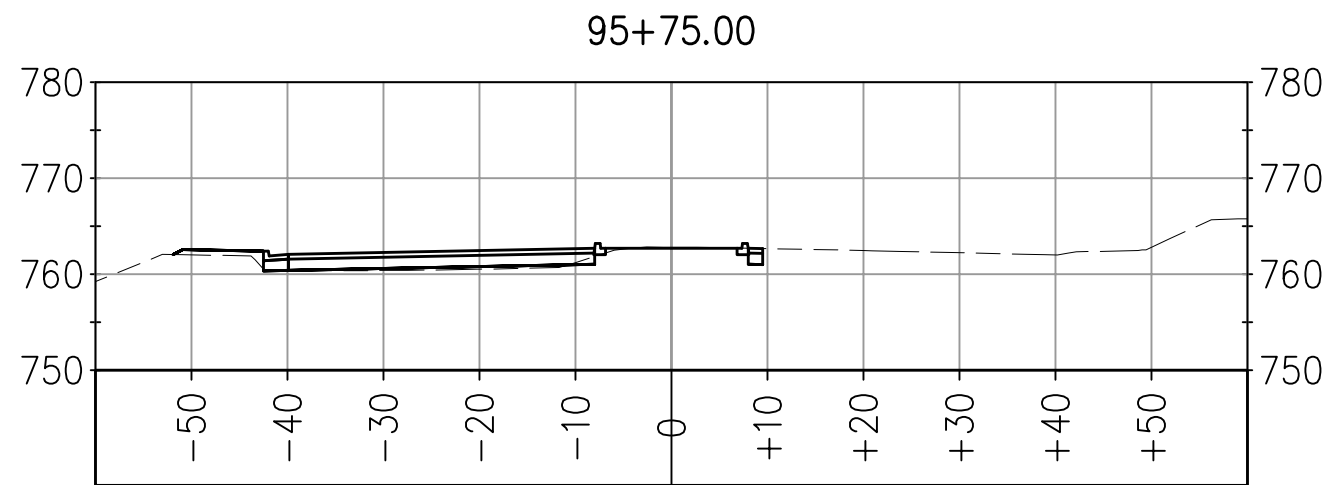

ALIGNMENT: SVP-E
 7-20-10
 DA
 SHEET 11 OF 15

NOTE: MODEL DOES NOT INCLUDE THE FOLLOWING:
 AB UNDER MEDIAN CURB
 AB LIMITS OFFSET FROM SAWCUT
 FINISHED GRADE BETWEEN MEDIAN CURBS

SILVA VALLEY PARKWAY WIDENING SOUTH OF ENTRADA DRIVE #72370
 EL DORADO COUNTY DEPARTMENT OF TRANSPORTATION

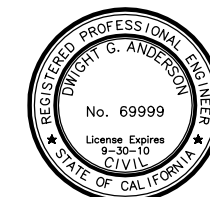

PREPARED UNDER THE SUPERVISION OF:
Dwight G. Anderson
 REGISTERED CIVIL ENGINEER
 DATE: 7-20-10

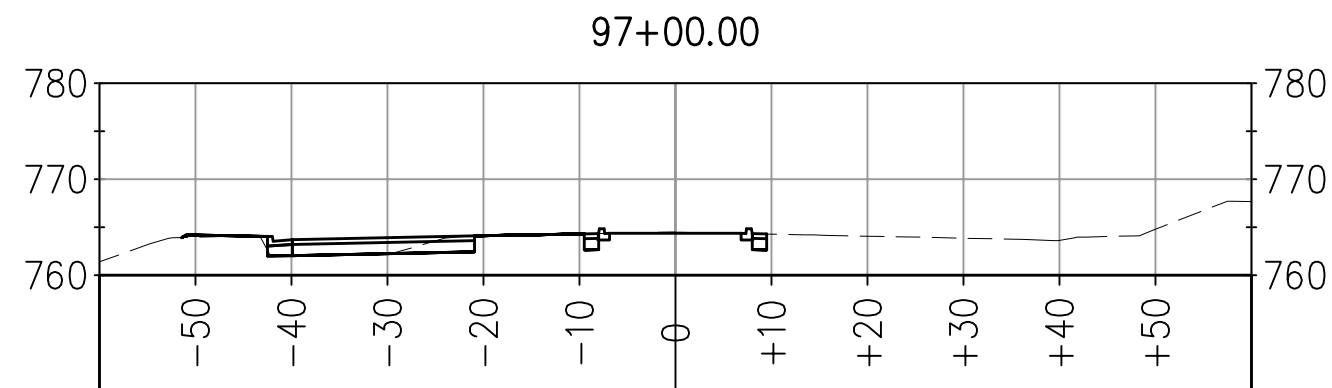
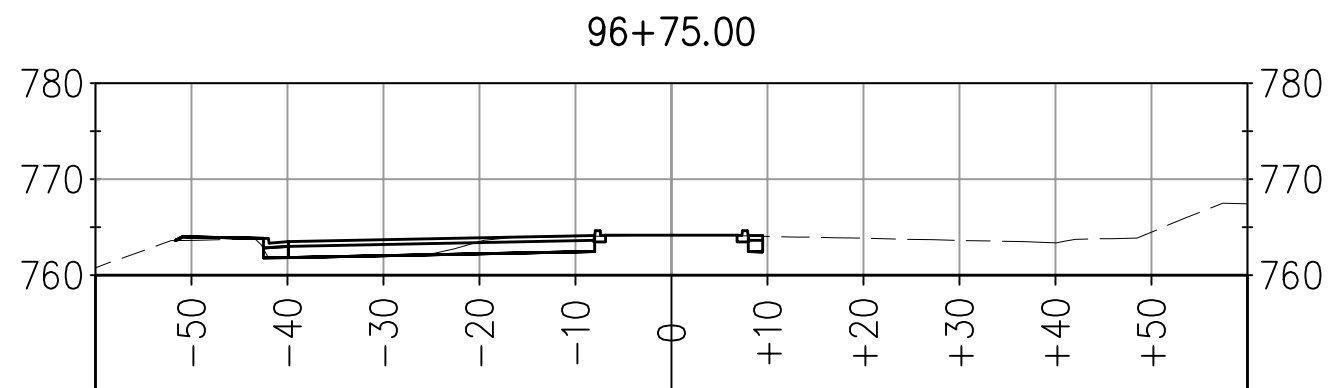
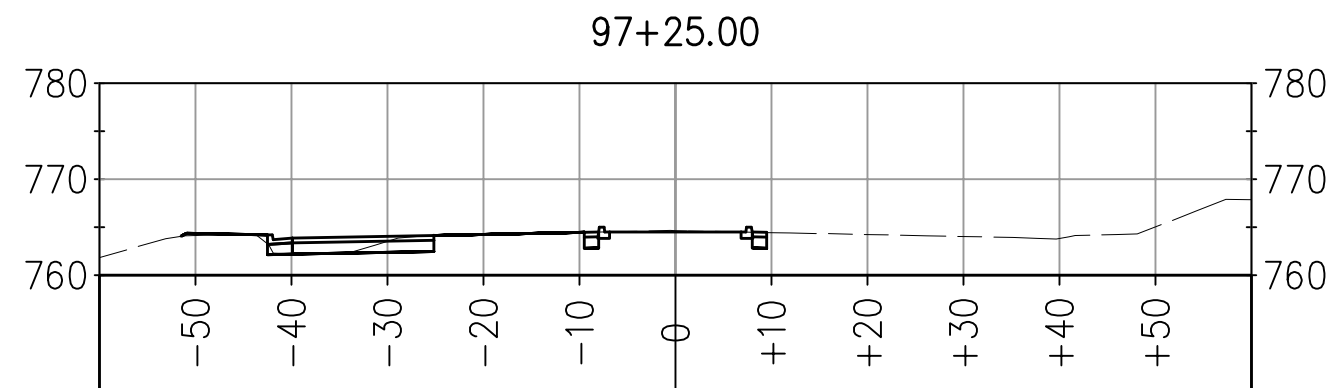
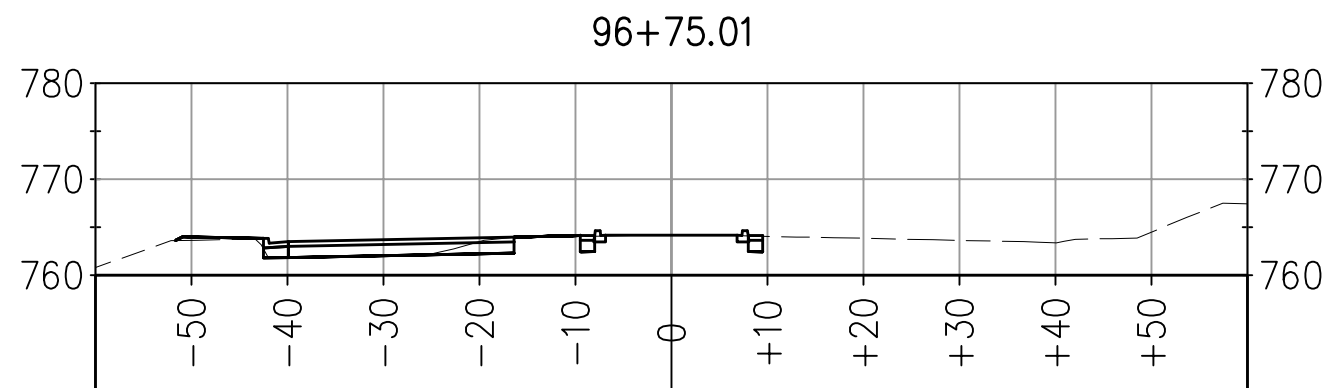
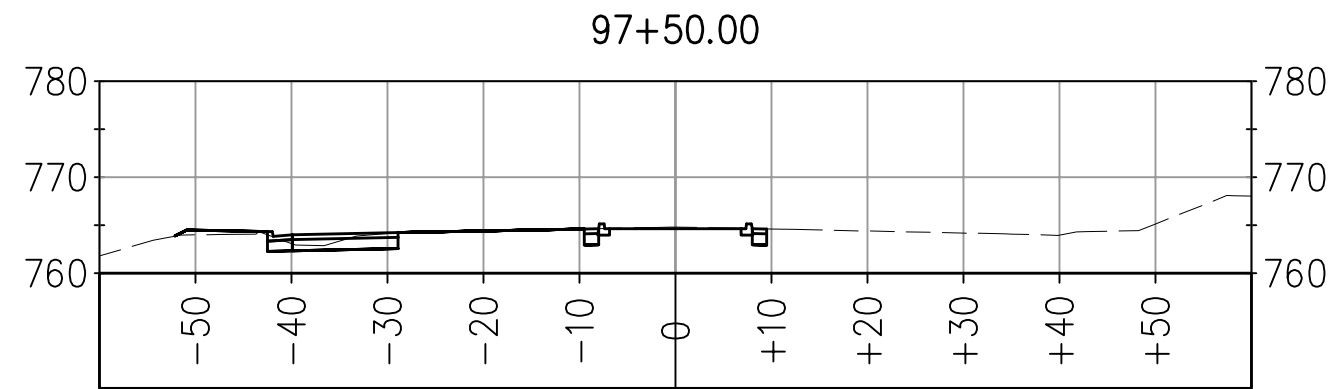
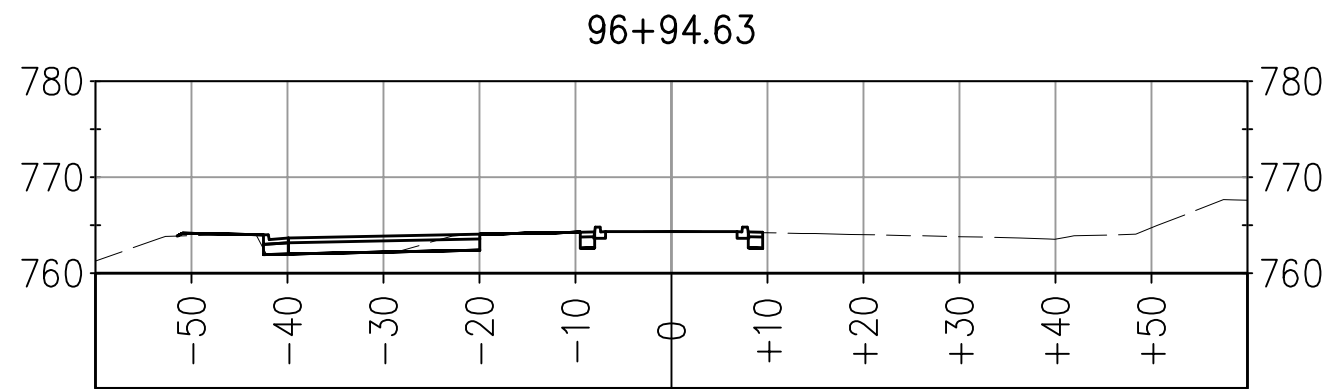

ALIGNMENT: SVP-E
 7-20-10
 DA
 SHEET 12 OF 15

NOTE: MODEL DOES NOT INCLUDE THE FOLLOWING:
 AB UNDER MEDIAN CURB
 AB LIMITS OFFSET FROM SAWCUT
 FINISHED GRADE BETWEEN MEDIAN CURBS

SILVA VALLEY PARKWAY WIDENING SOUTH OF ENTRADA DRIVE #72370
 EL DORADO COUNTY DEPARTMENT OF TRANSPORTATION



PREPARED UNDER THE SUPERVISION OF :

Dwight G. Anderson

REGISTERED CIVIL ENGINEER

7-20-10
 DATE:

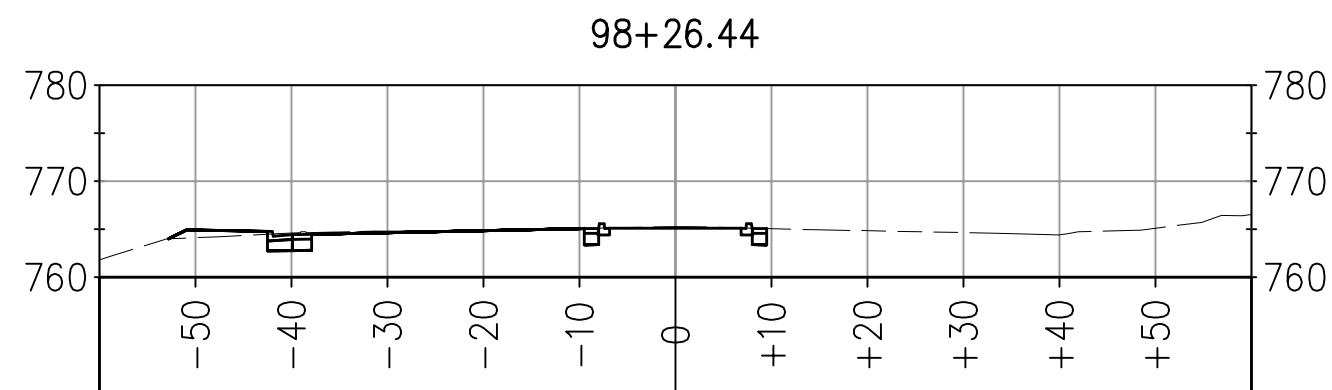
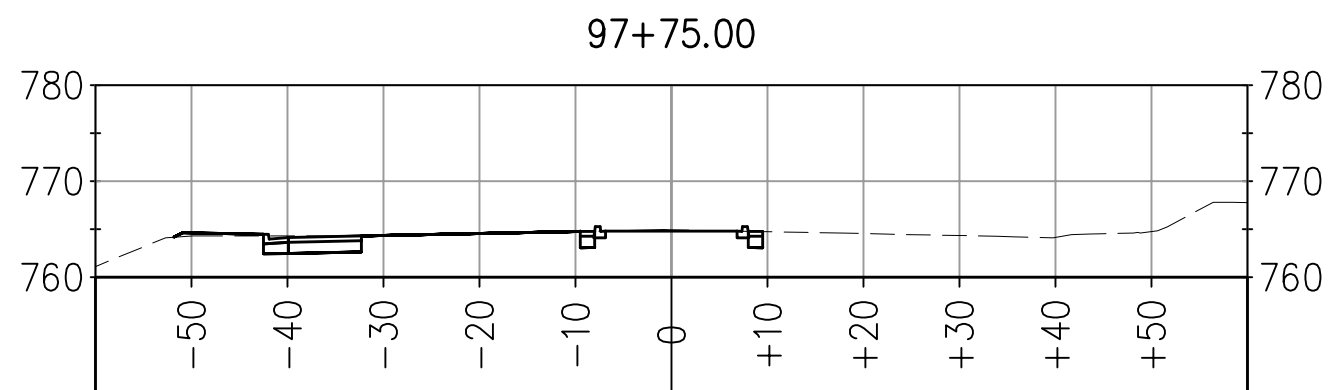
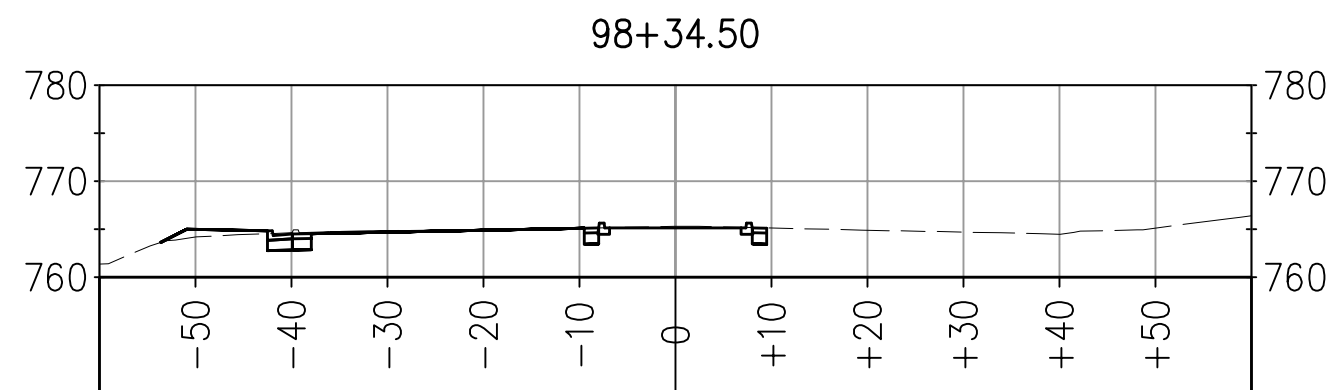
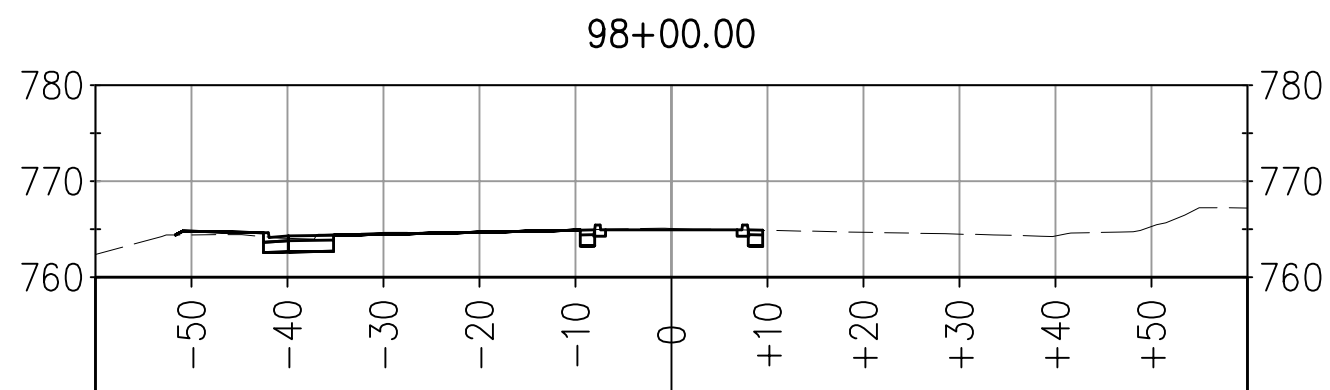
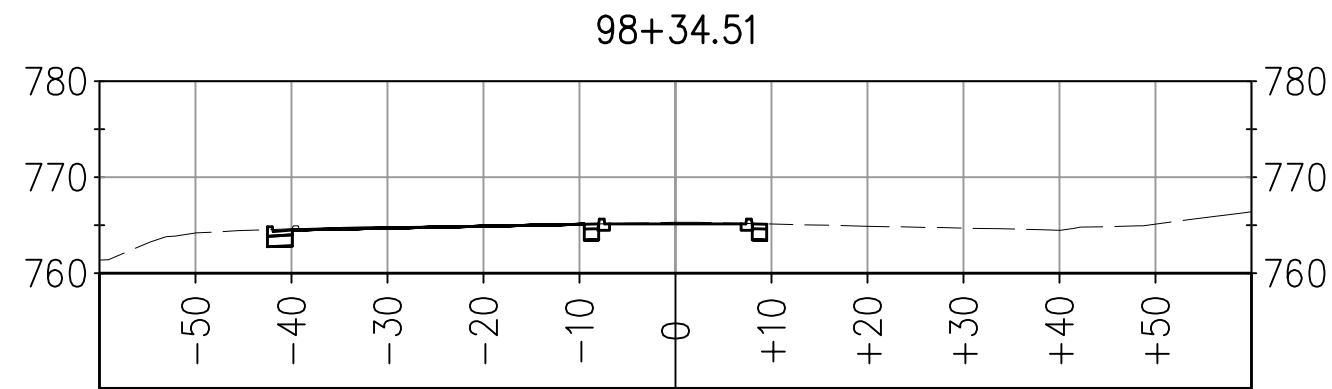
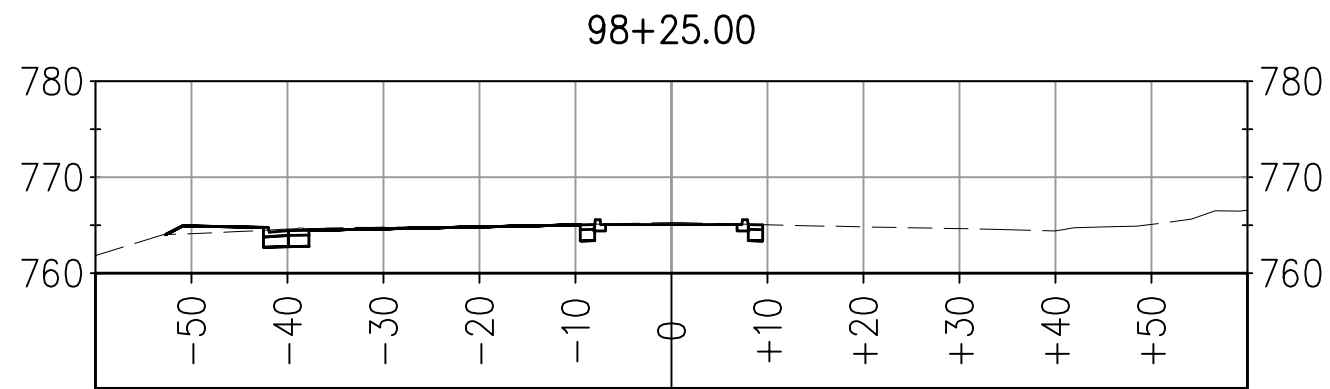

ALIGNMENT: SVP-E
 7-20-10
 DA
 SHEET 13 OF 15

NOTE: MODEL DOES NOT INCLUDE THE FOLLOWING:
 AB UNDER MEDIAN CURB
 AB LIMITS OFFSET FROM SAWCUT
 FINISHED GRADE BETWEEN MEDIAN CURBS

SILVA VALLEY PARKWAY WIDENING SOUTH OF ENTRADA DRIVE #72370
 EL DORADO COUNTY DEPARTMENT OF TRANSPORTATION



PREPARED UNDER THE SUPERVISION OF :

Dwight G. Anderson
 REGISTERED CIVIL ENGINEER

7-20-10
 DATE:

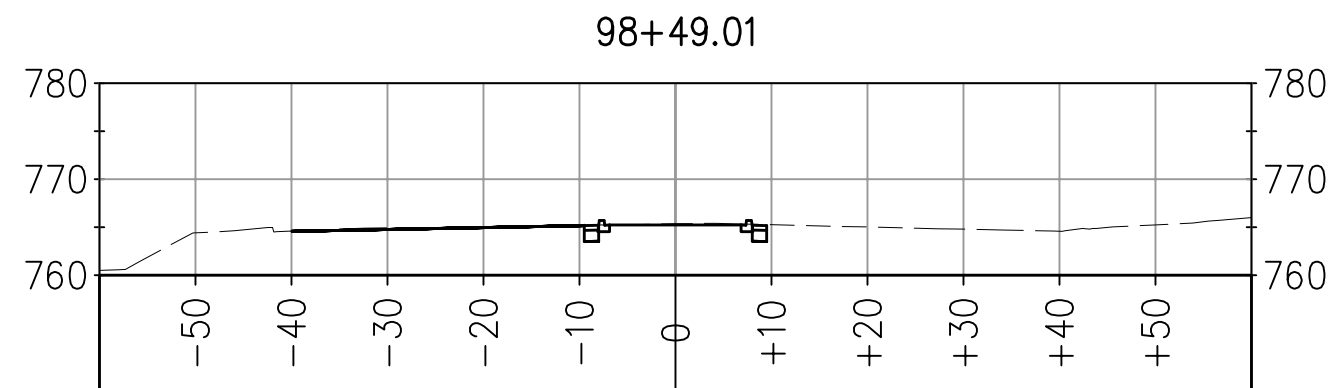
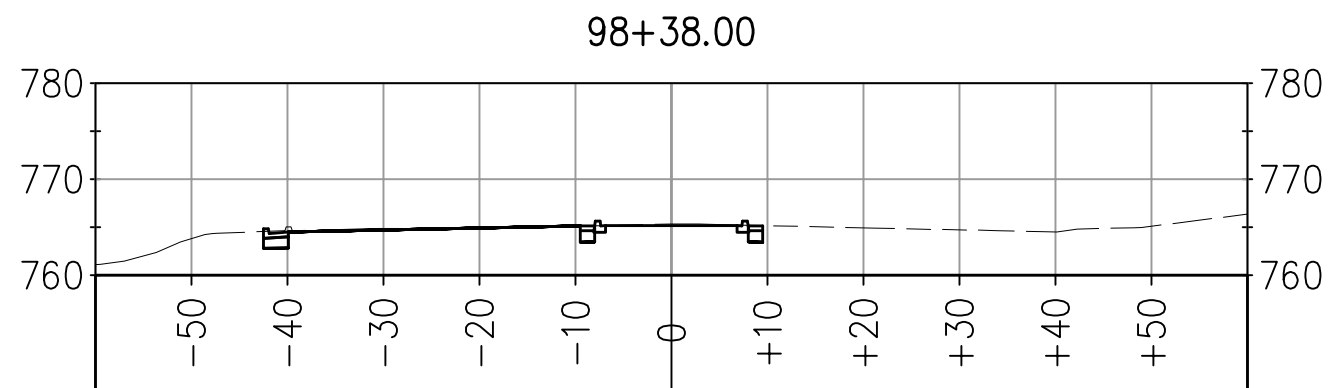
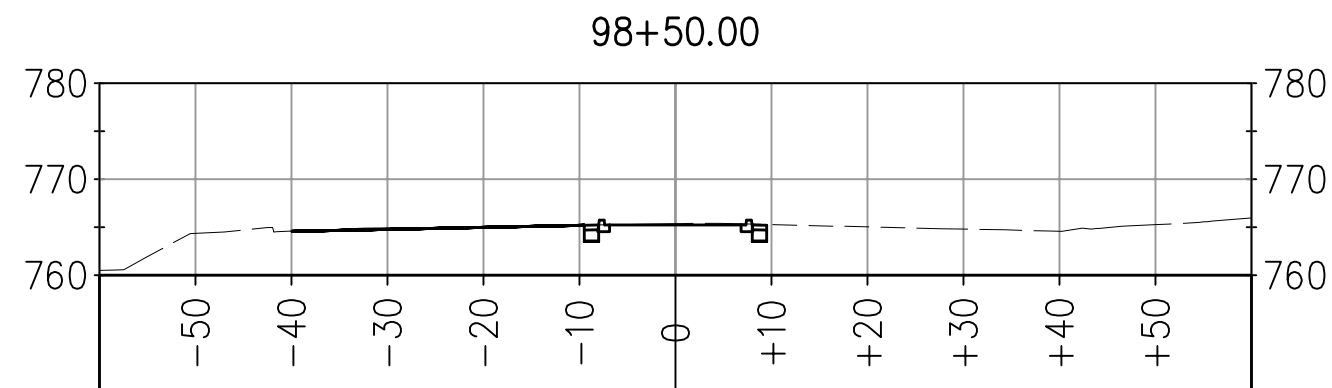
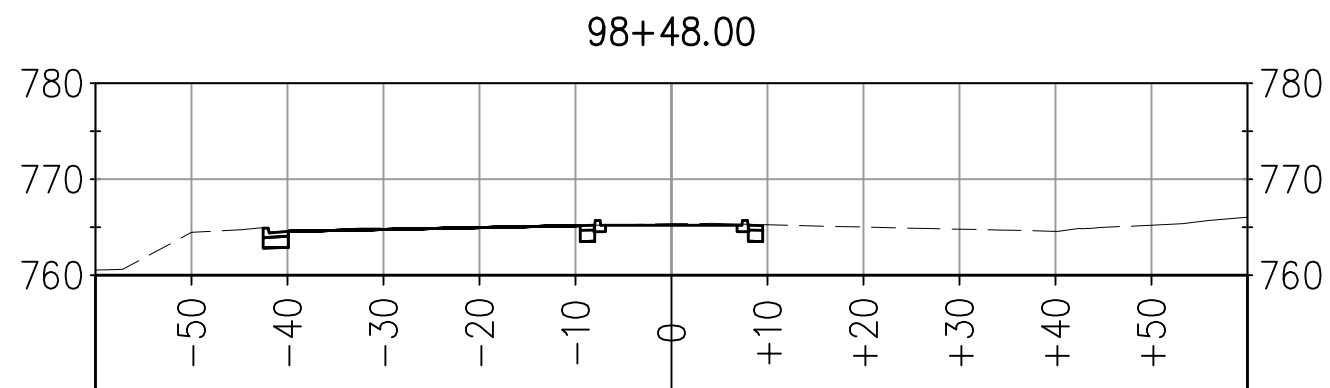
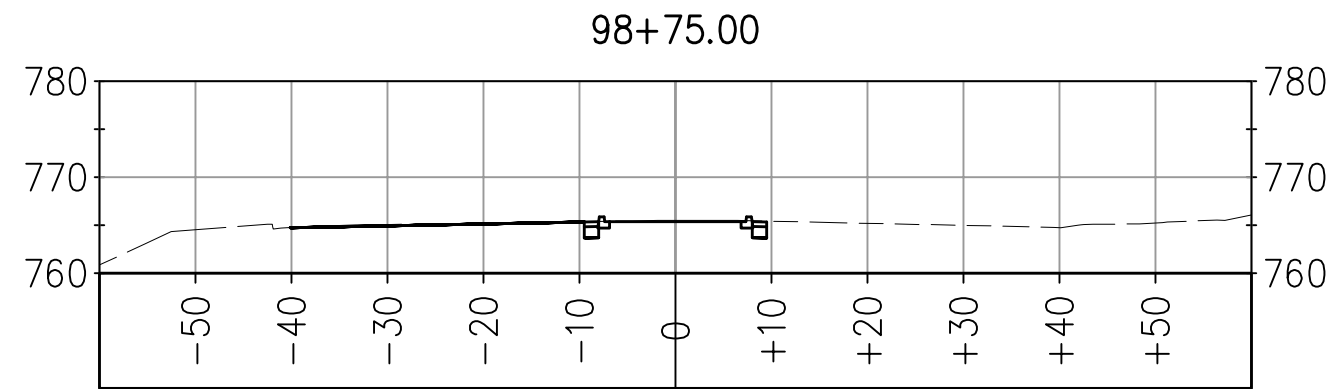
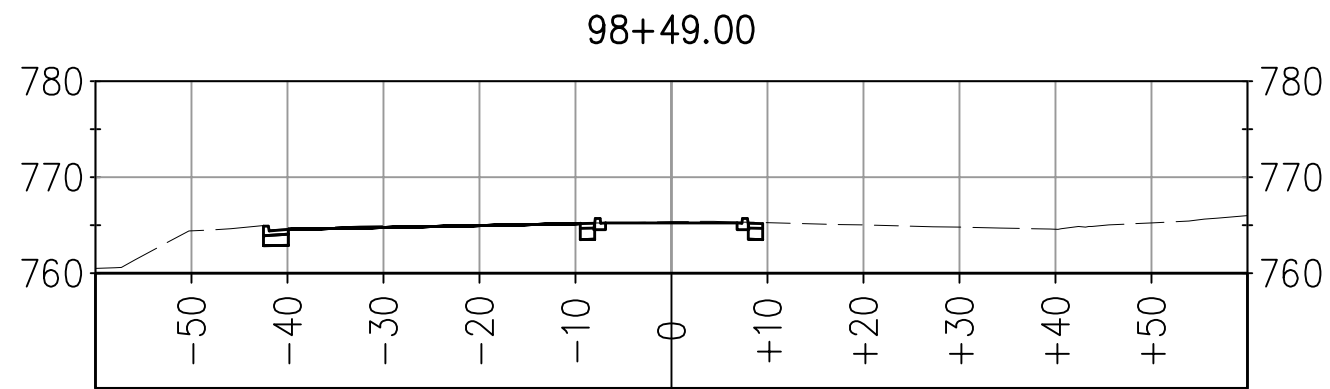

ALIGNMENT: SVP-E
 7-20-10
 DA
 SHEET 14 OF 15

NOTE: MODEL DOES NOT INCLUDE THE FOLLOWING:
 AB UNDER MEDIAN CURB
 AB LIMITS OFFSET FROM SAWCUT
 FINISHED GRADE BETWEEN MEDIAN CURBS

SILVA VALLEY PARKWAY WIDENING SOUTH OF ENTRADA DRIVE #72370
 EL DORADO COUNTY DEPARTMENT OF TRANSPORTATION



PREPARED UNDER THE SUPERVISION OF :

Dwight G. Anderson
 REGISTERED CIVIL ENGINEER

7-20-10
 DATE:

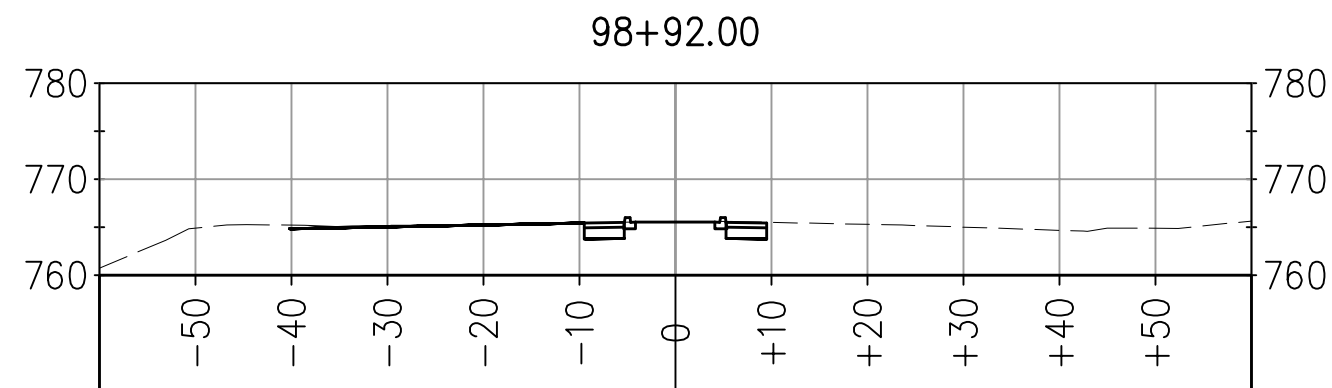
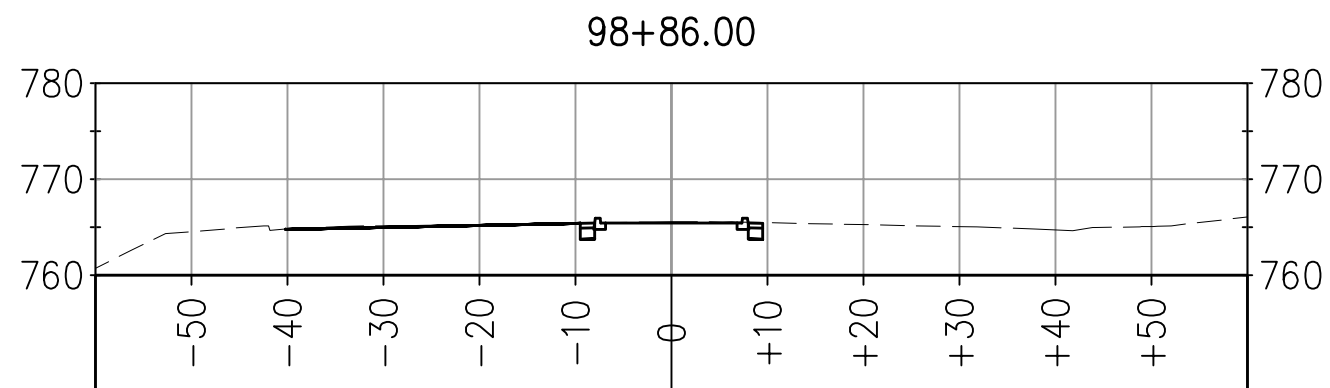
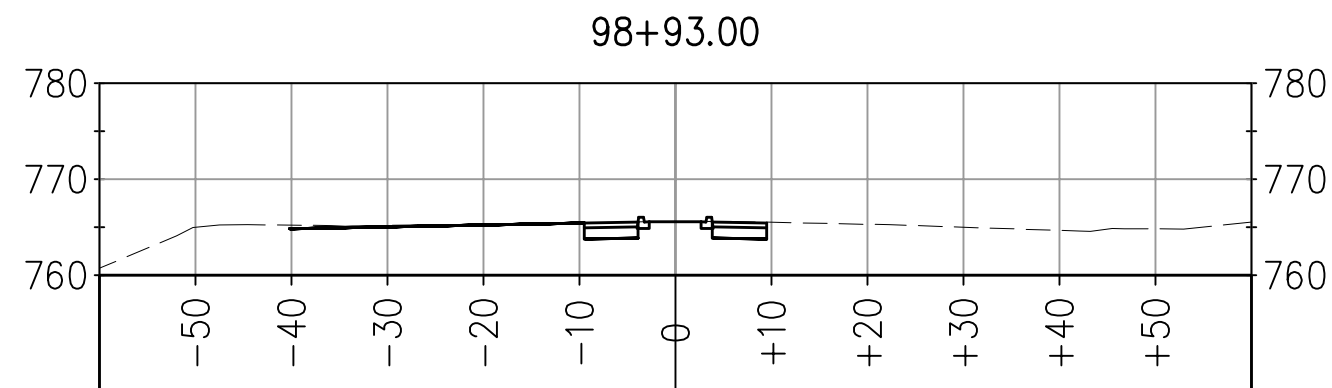
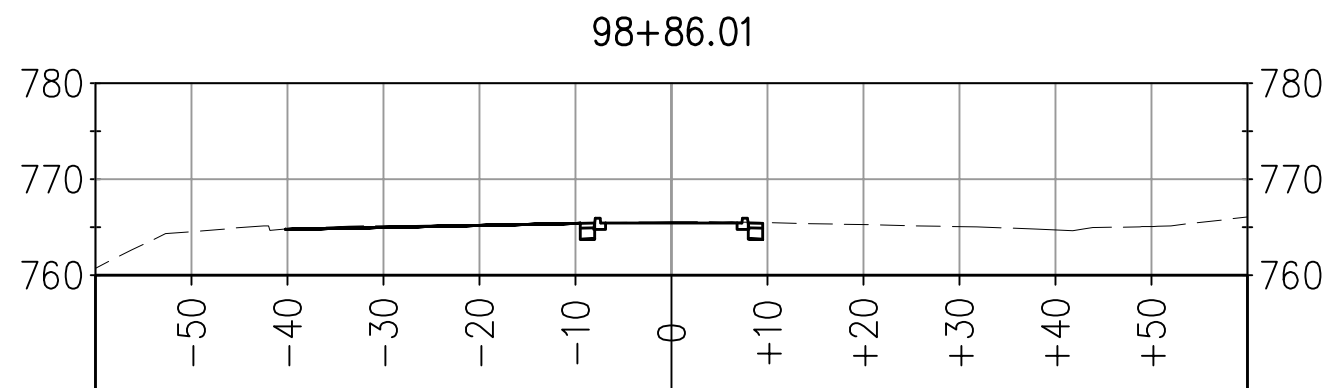
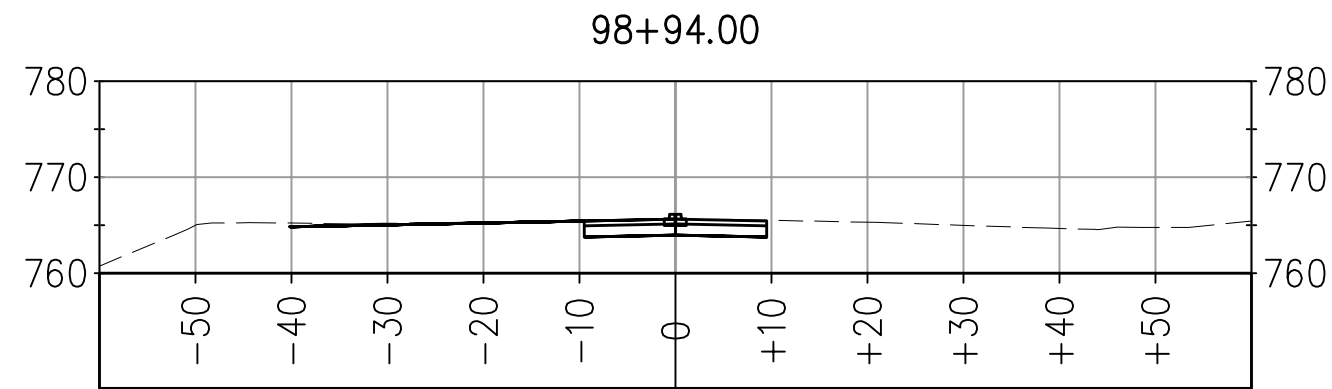
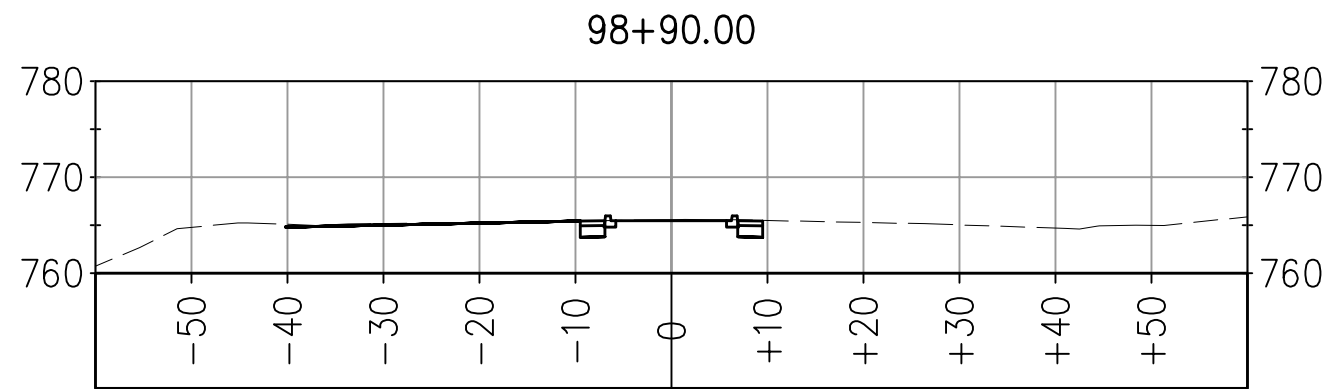

ALIGNMENT: SVP-E
 7-20-10
 DA
 SHEET 15 OF 15

NOTE: MODEL DOES NOT INCLUDE THE FOLLOWING:
 AB UNDER MEDIAN CURB
 AB LIMITS OFFSET FROM SAWCUT
 FINISHED GRADE BETWEEN MEDIAN CURBS

SILVA VALLEY PARKWAY WIDENING SOUTH OF ENTRADA DRIVE #72370
 EL DORADO COUNTY DEPARTMENT OF TRANSPORTATION



PREPARED UNDER THE SUPERVISION OF :

Dwight G. Anderson

REGISTERED CIVIL ENGINEER

7-20-10
 DATE:

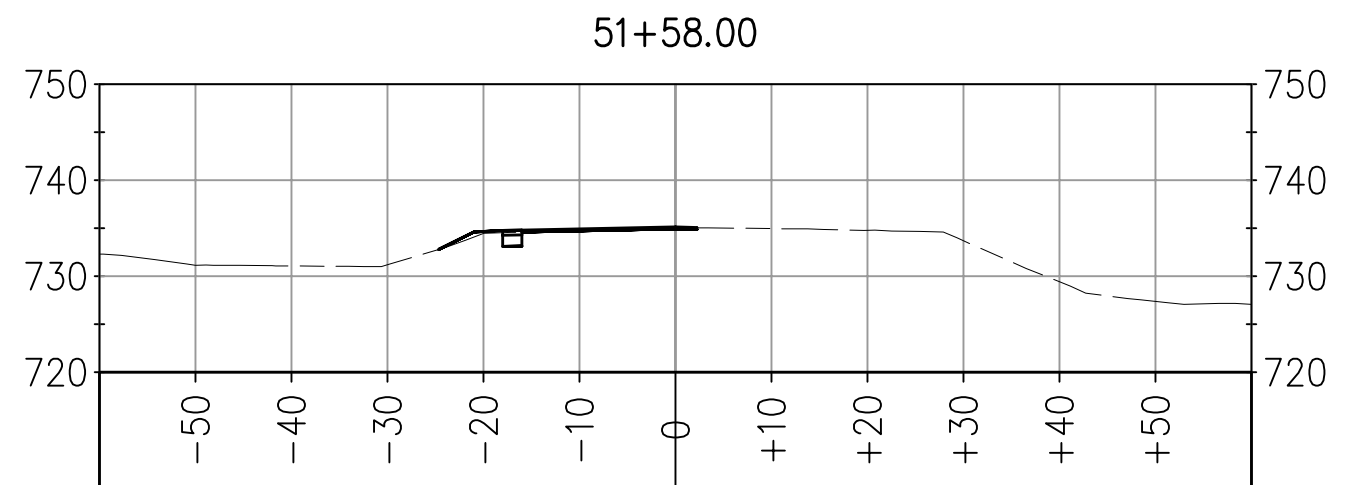
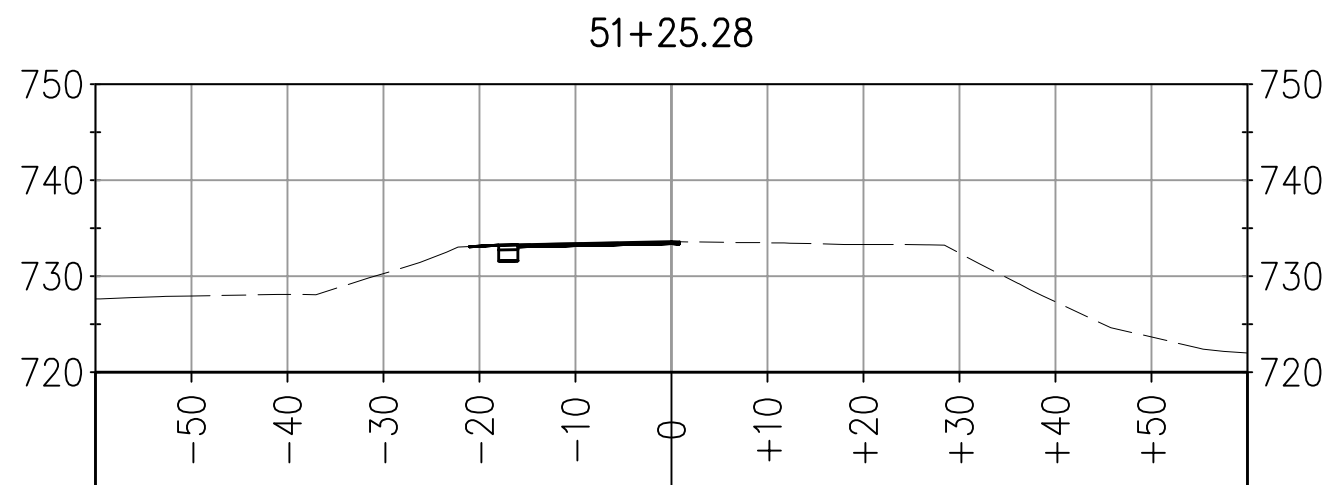
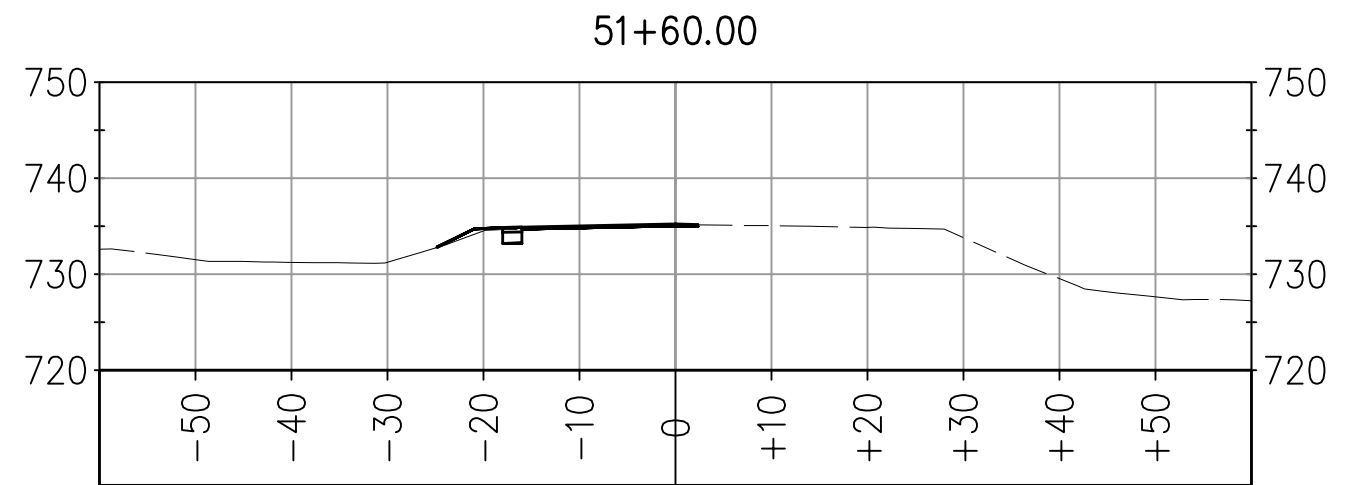
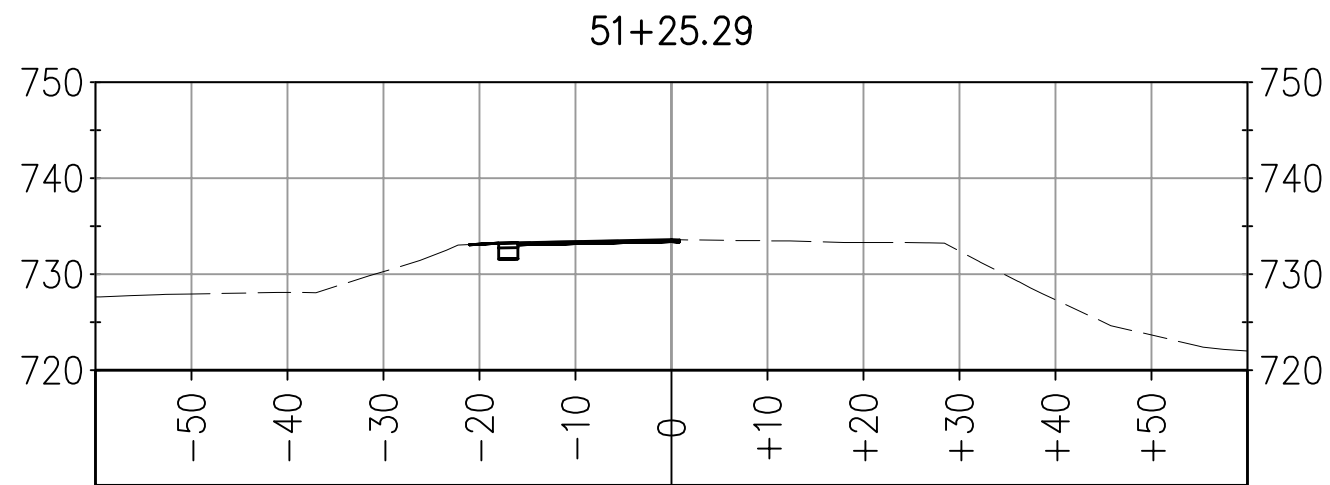
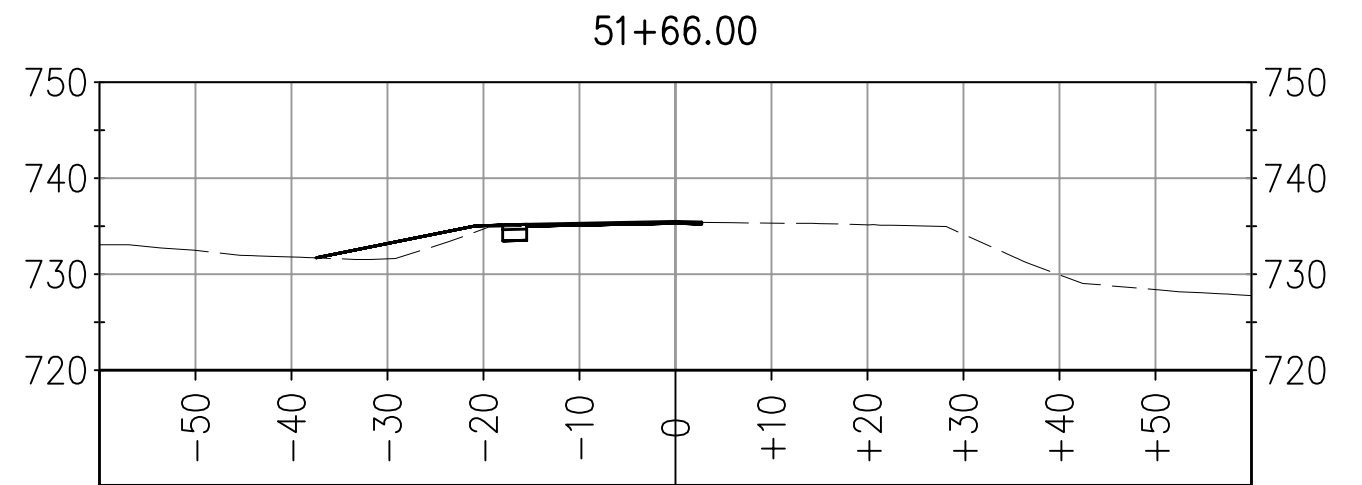
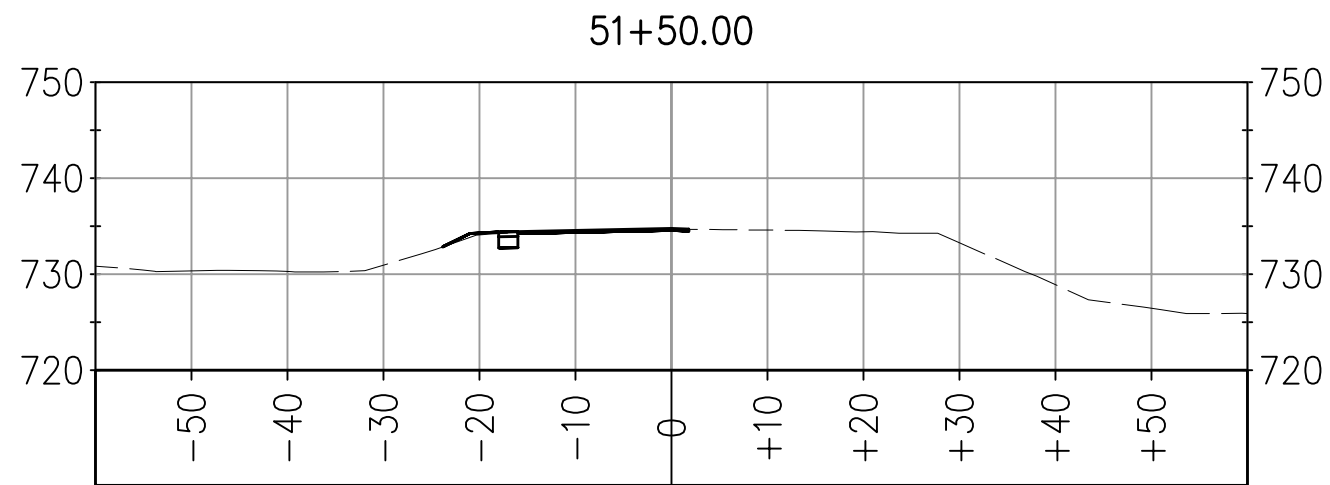

ALIGNMENT: SVP-F
 7-20-10
 DA
 SHEET 1 OF 6

MODEL DOES NOT INCLUDE THE FOLLOWING:
 RIP RAP
 DITCH TRANSITION
 AB LIMITS OFFSET FROM SAWCUT

SILVA VALLEY PARKWAY WIDENING SOUTH OF ENTRADA DRIVE #72370
 EL DORADO COUNTY DEPARTMENT OF TRANSPORTATION



PREPARED UNDER THE SUPERVISION OF :

Dwight G. Anderson

REGISTERED CIVIL ENGINEER

7-20-10
 DATE:

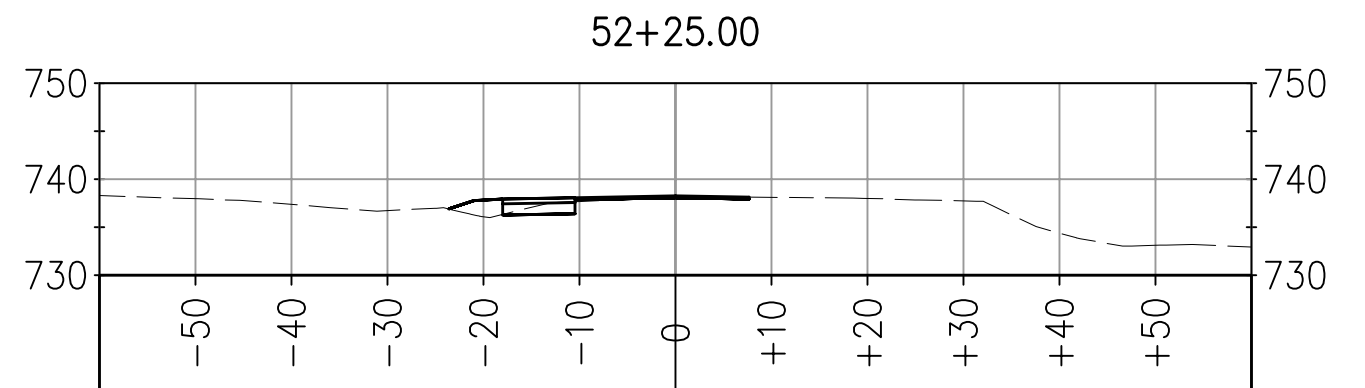
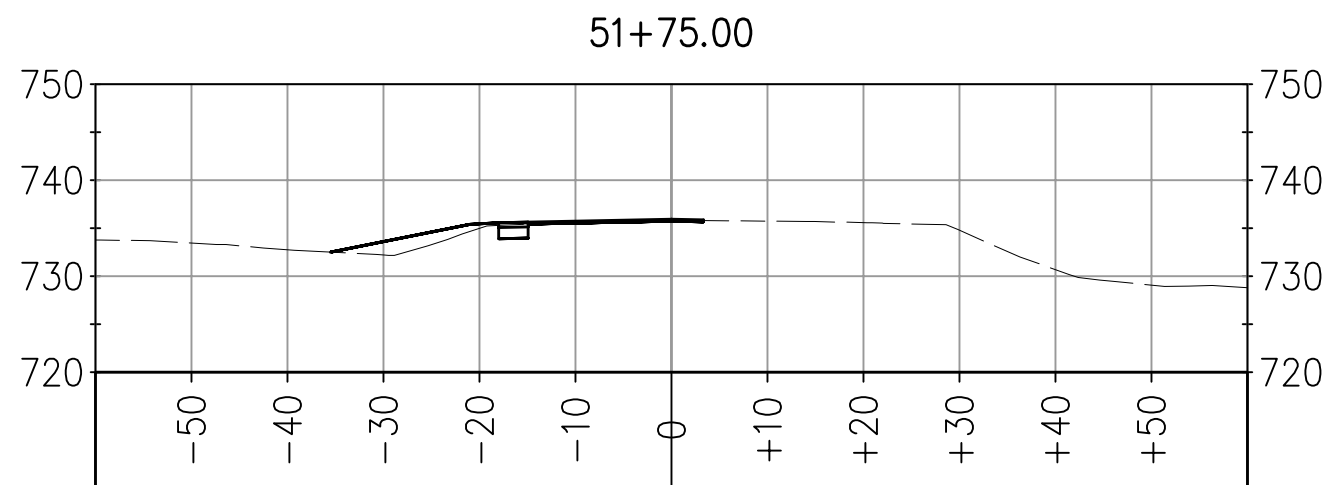
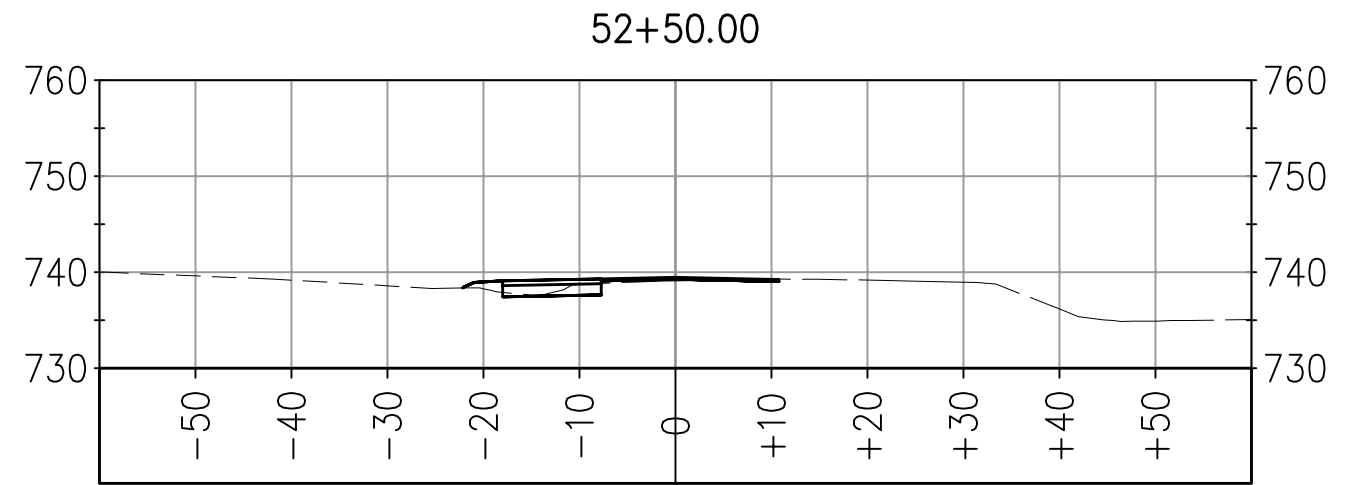
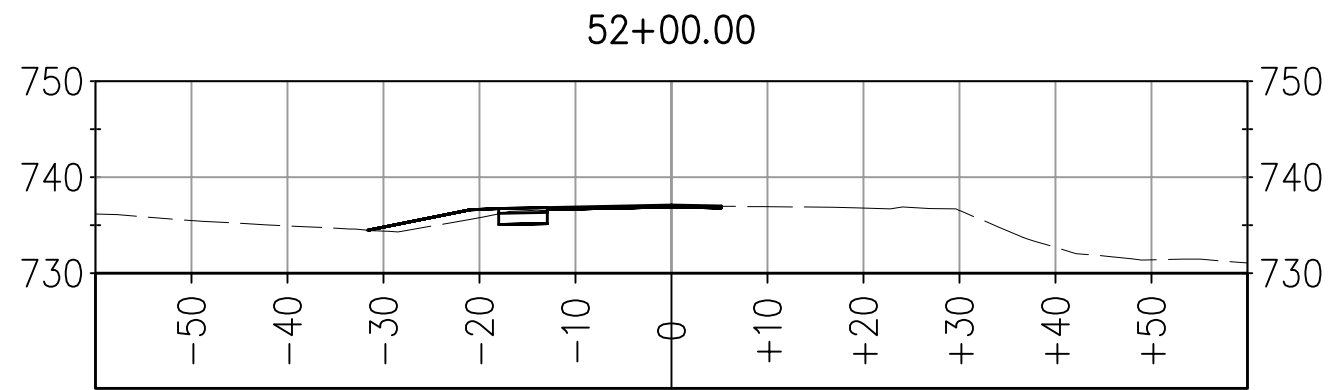
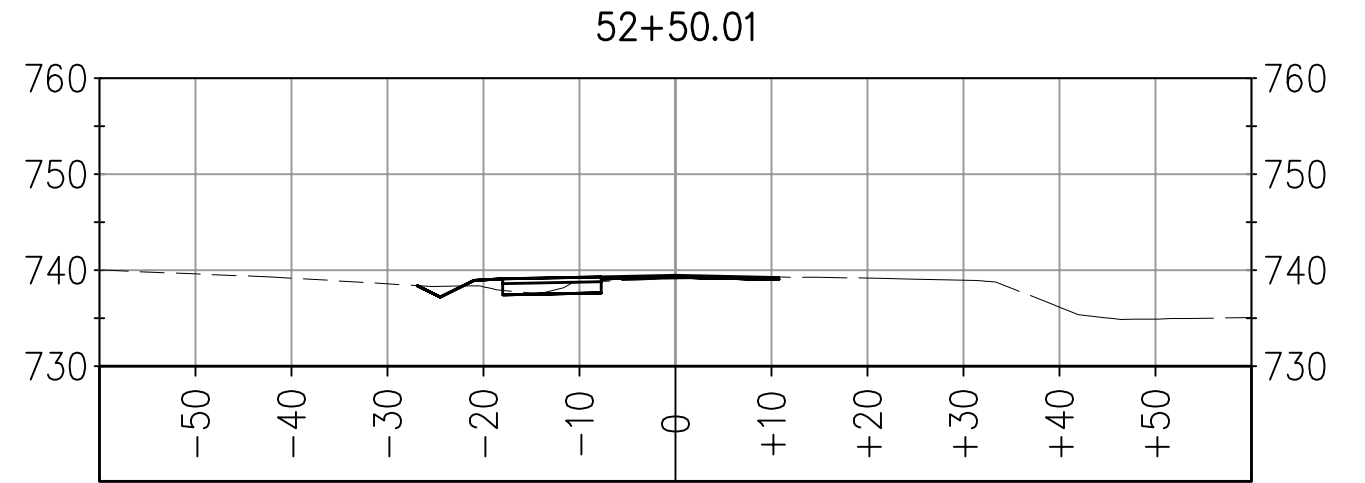
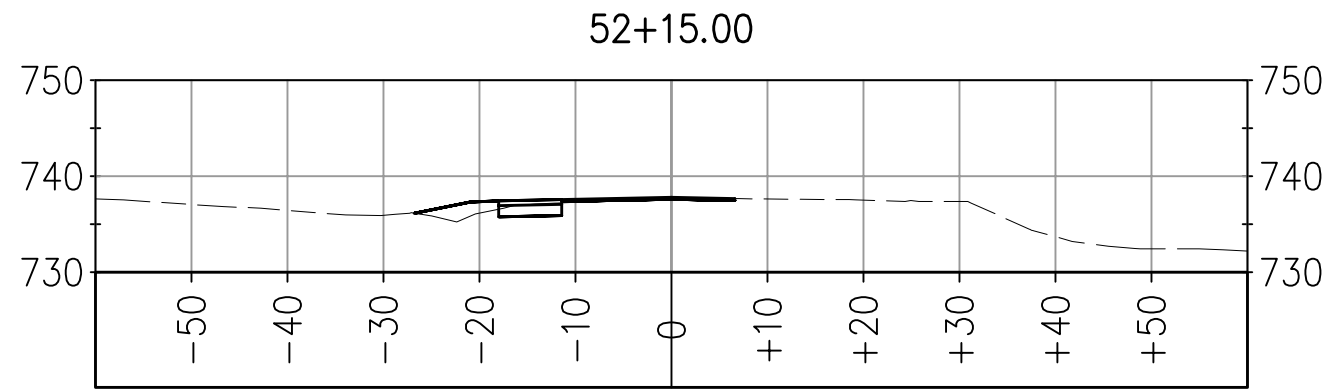

ALIGNMENT: SVP-F
 7-20-10
 DA
 SHEET 2 OF 6

MODEL DOES NOT INCLUDE THE FOLLOWING:
 RIP RAP
 DITCH TRANSITION
 AB LIMITS OFFSET FROM SAWCUT

SILVA VALLEY PARKWAY WIDENING SOUTH OF ENTRADA DRIVE #72370
 EL DORADO COUNTY DEPARTMENT OF TRANSPORTATION



PREPARED UNDER THE SUPERVISION OF :

Dwight G. Anderson

REGISTERED CIVIL ENGINEER

7-20-10
 DATE:

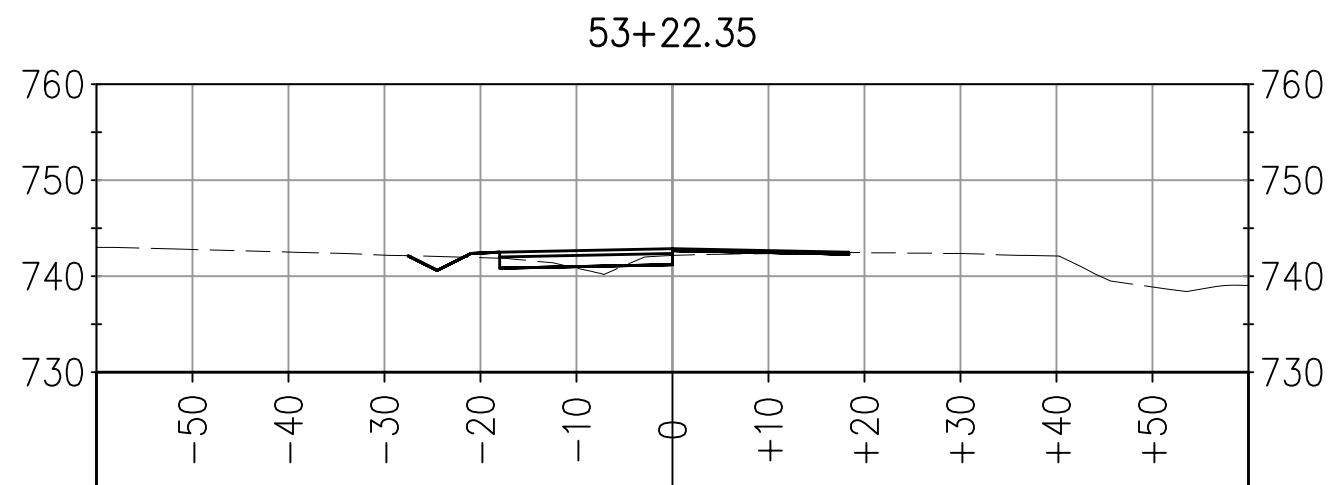
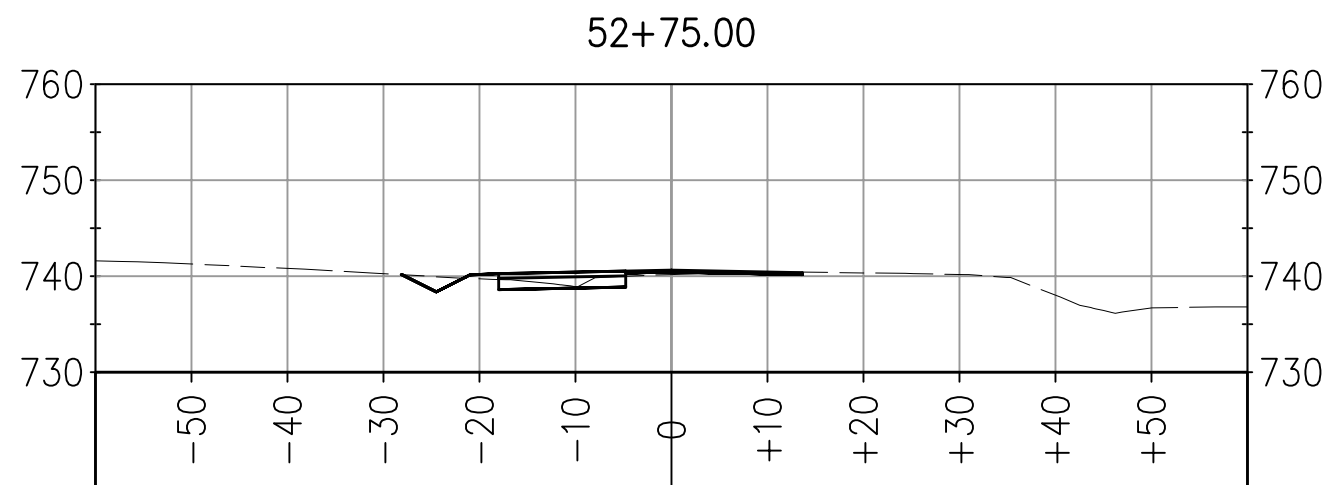
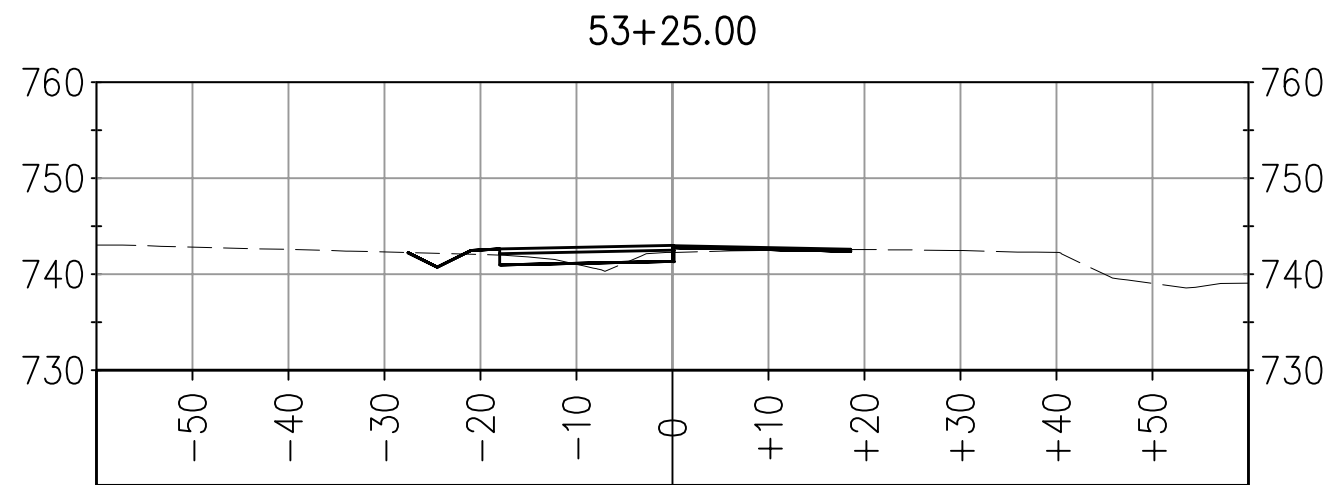
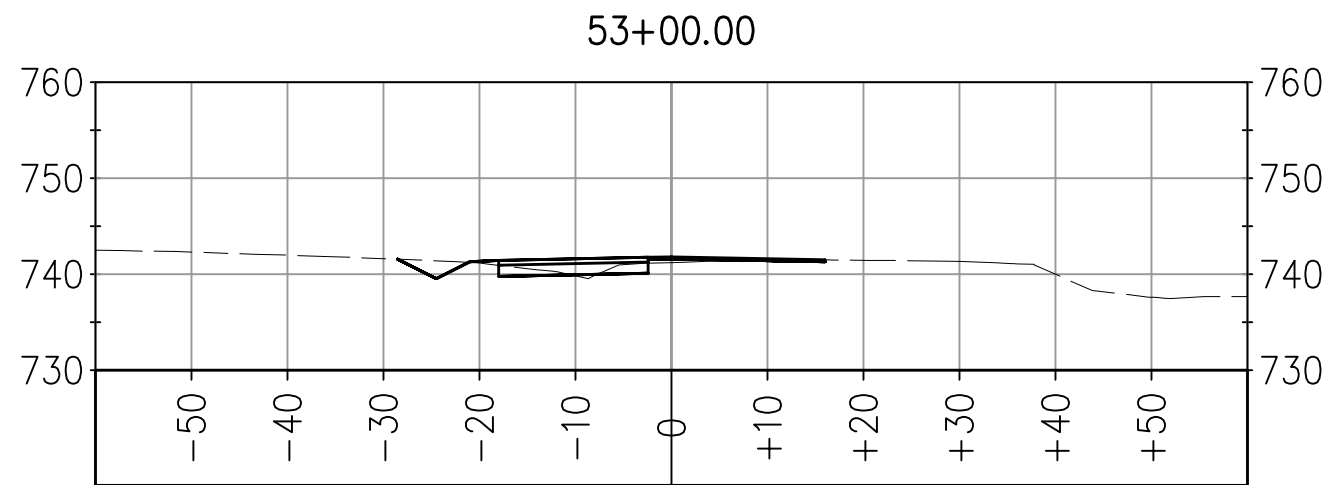
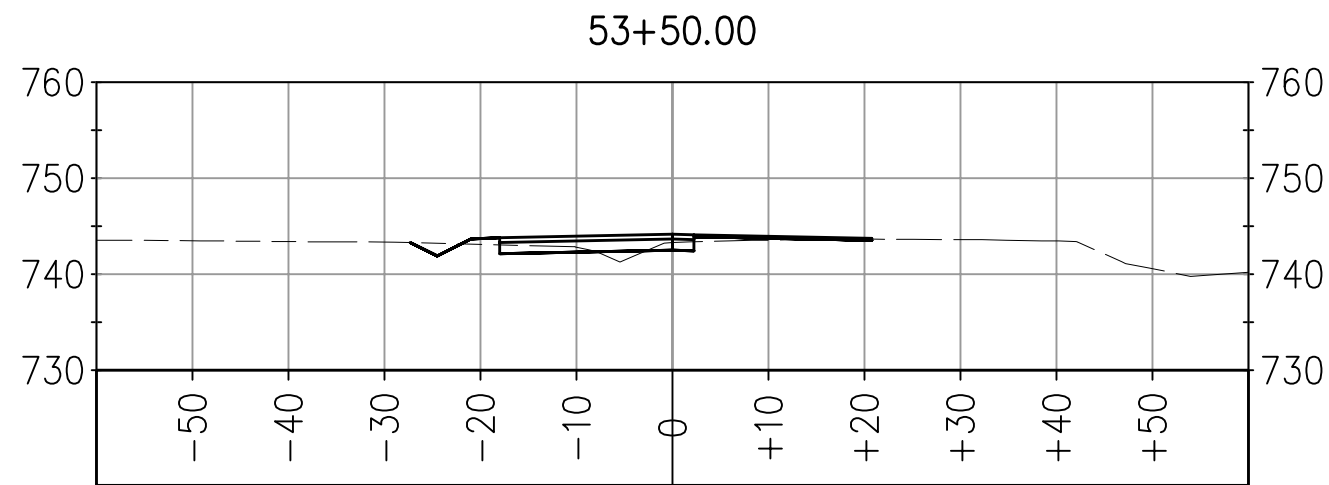
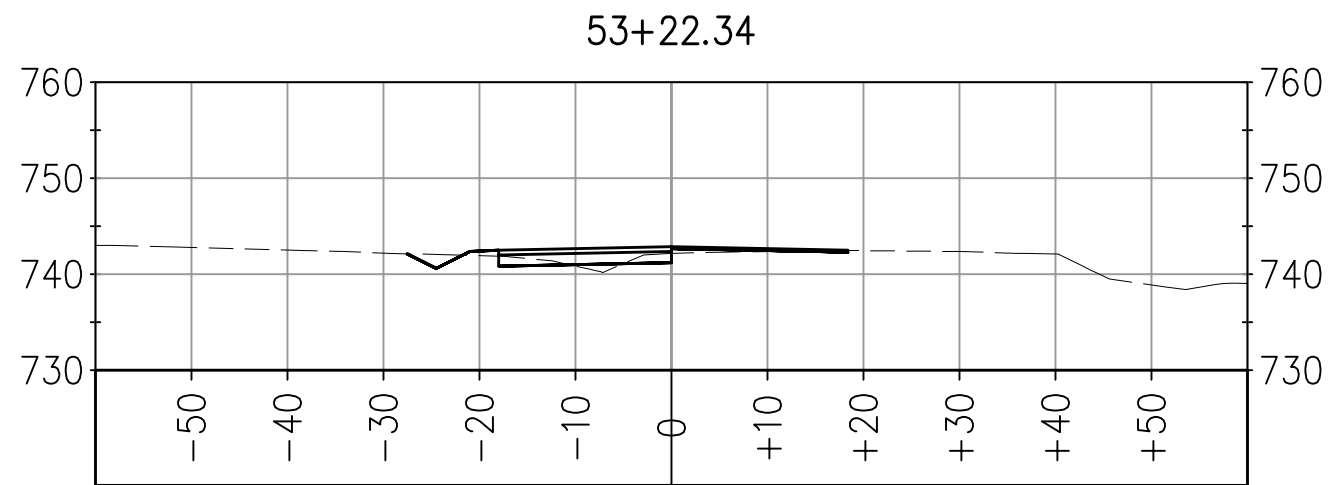

ALIGNMENT: SVP-F
 7-20-10
 DA
 SHEET 3 OF 6

MODEL DOES NOT INCLUDE THE FOLLOWING:
 RIP RAP
 DITCH TRANSITION
 AB LIMITS OFFSET FROM SAWCUT

SILVA VALLEY PARKWAY WIDENING SOUTH OF ENTRADA DRIVE #72370
 EL DORADO COUNTY DEPARTMENT OF TRANSPORTATION

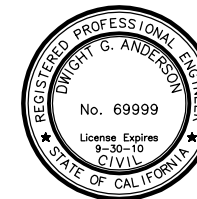

PREPARED UNDER THE SUPERVISION OF :

Dwight G. Anderson

REGISTERED CIVIL ENGINEER

7-20-10
 DATE:

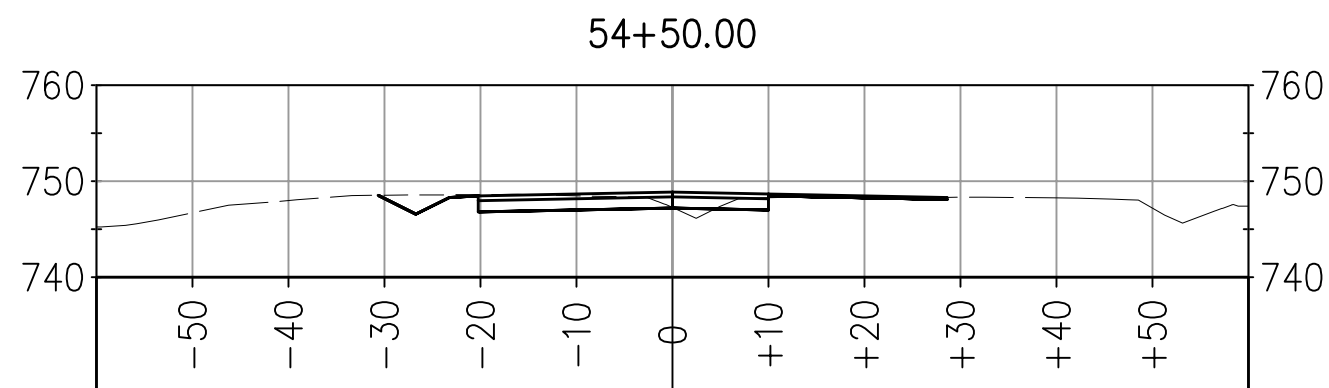
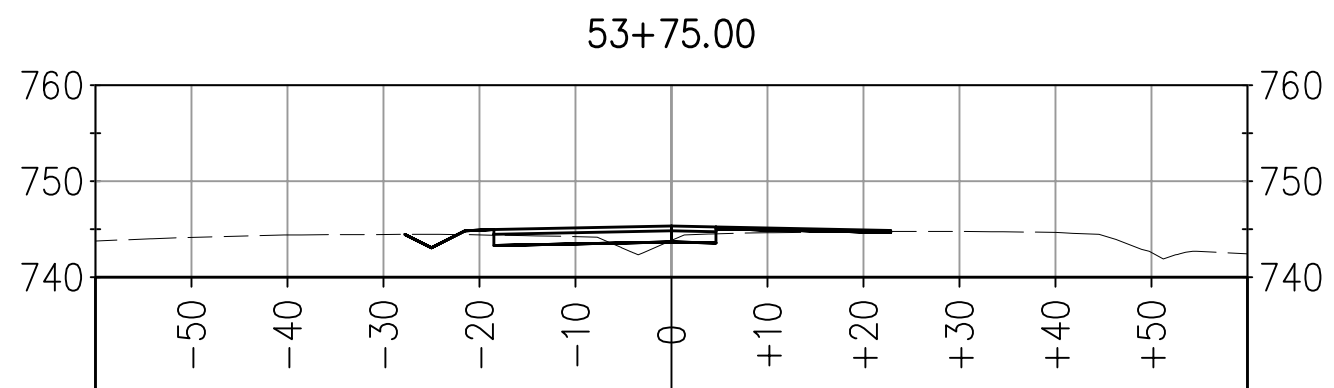
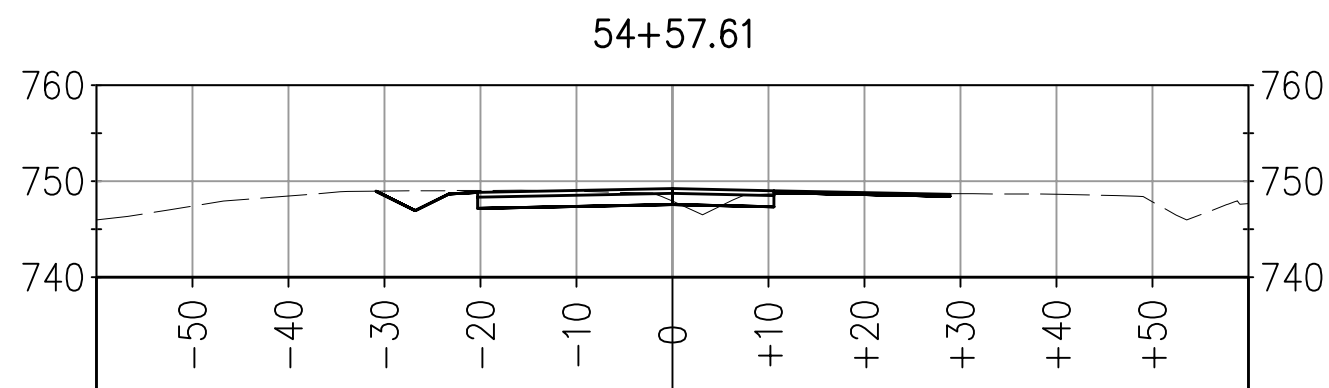
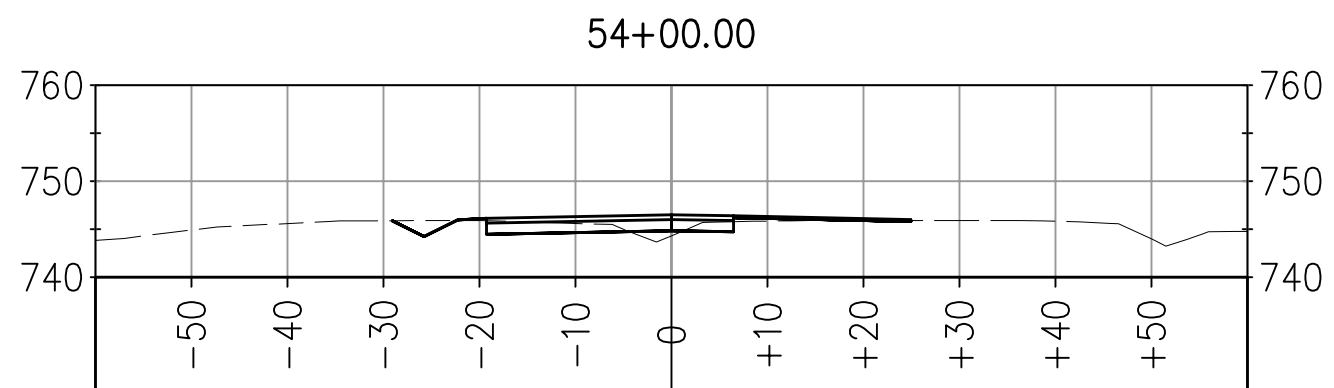
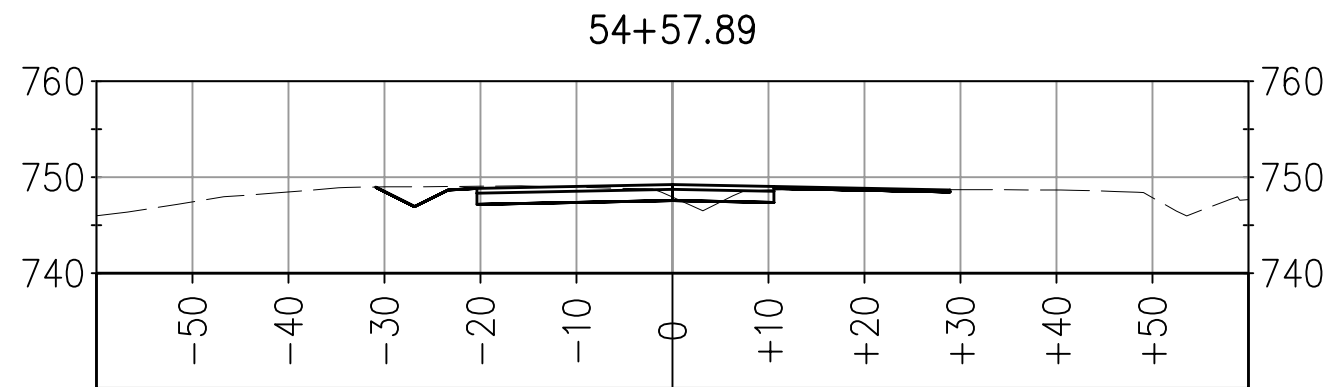
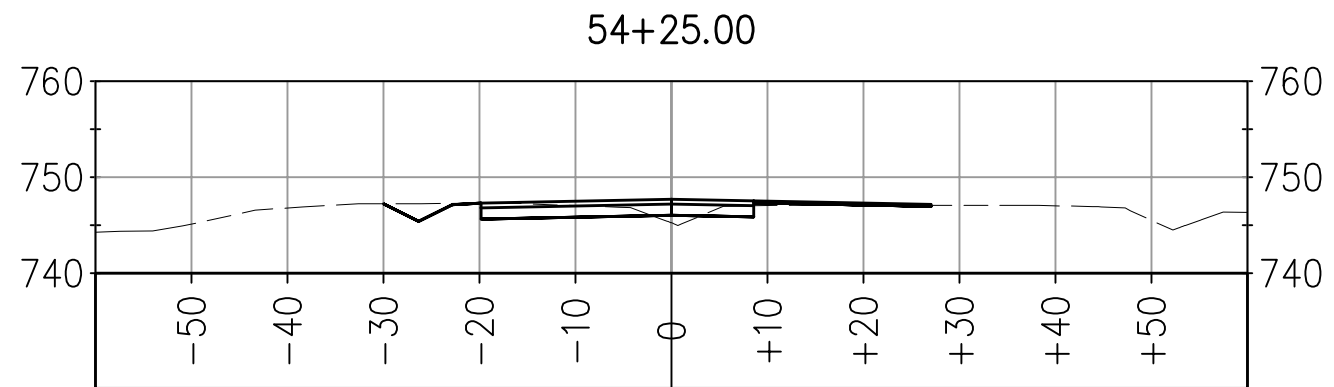

ALIGNMENT: SVP-F
 7-20-10
 DA
 SHEET 4 OF 6

MODEL DOES NOT INCLUDE THE FOLLOWING:
 RIP RAP
 DITCH TRANSITION
 AB LIMITS OFFSET FROM SAWCUT

SILVA VALLEY PARKWAY WIDENING SOUTH OF ENTRADA DRIVE #72370
 EL DORADO COUNTY DEPARTMENT OF TRANSPORTATION

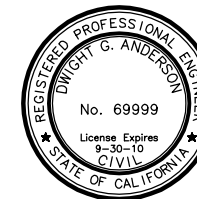

PREPARED UNDER THE SUPERVISION OF :

Dwight G. Anderson
 REGISTERED CIVIL ENGINEER

7-20-10
 DATE:

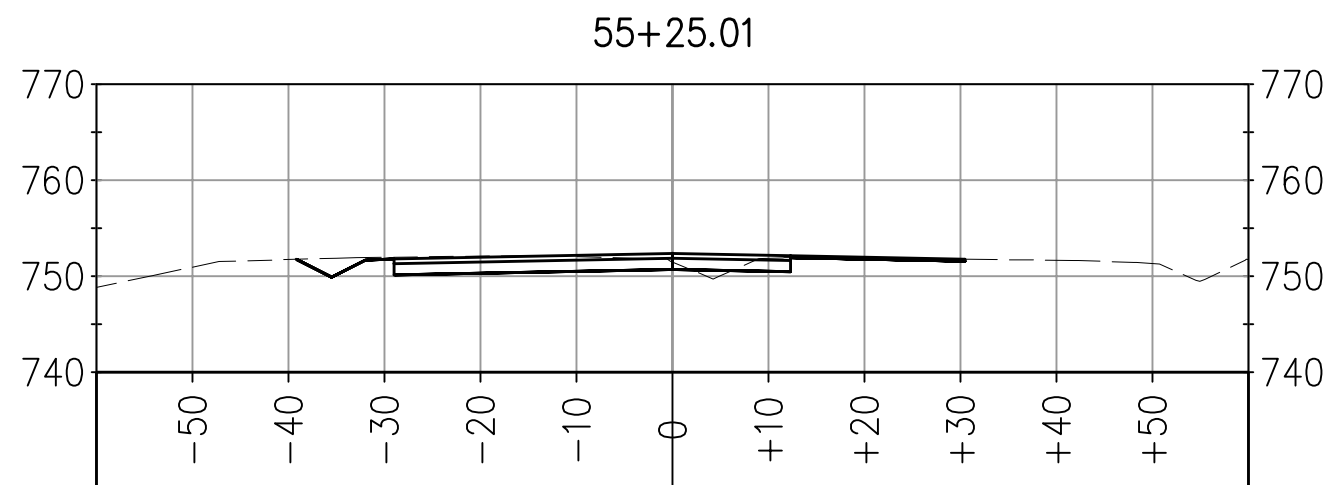
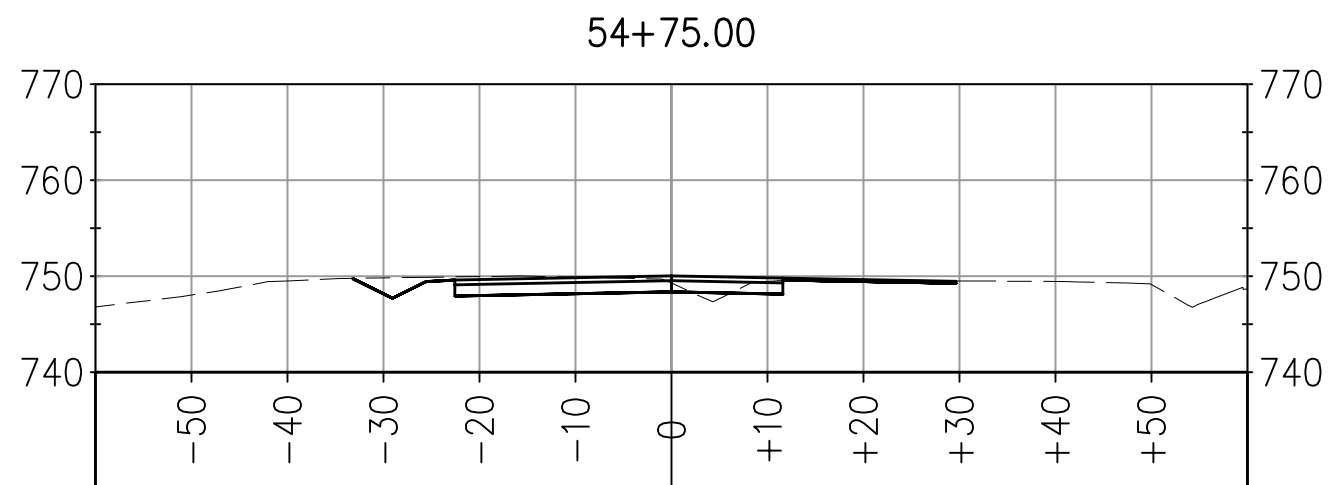
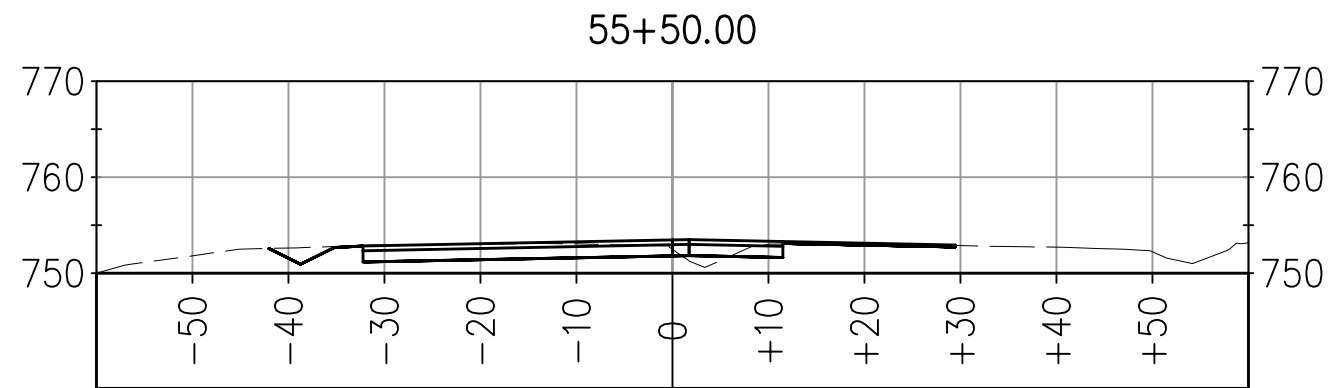
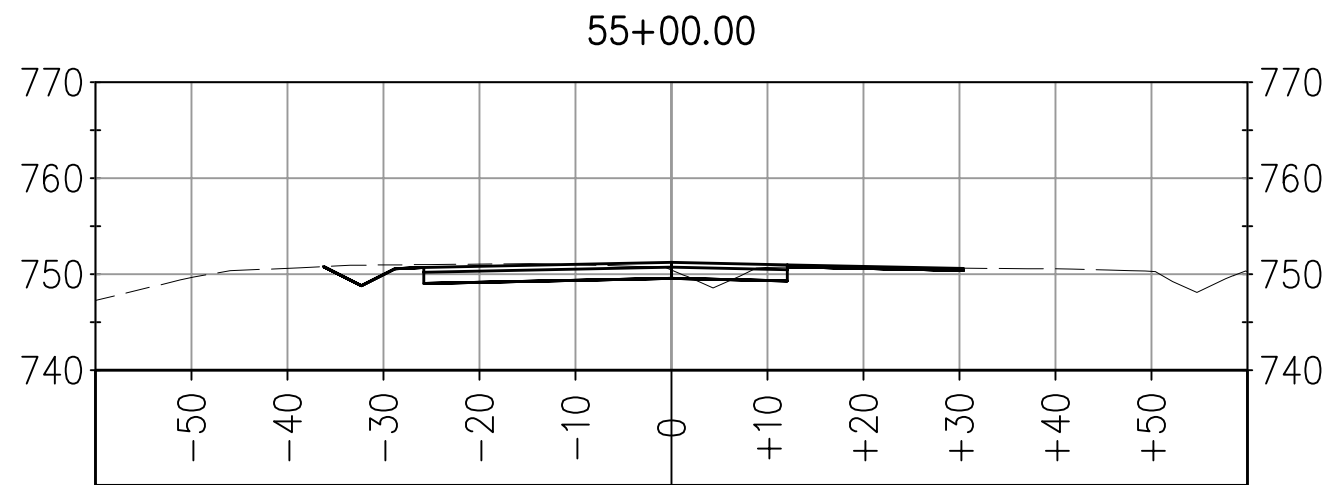
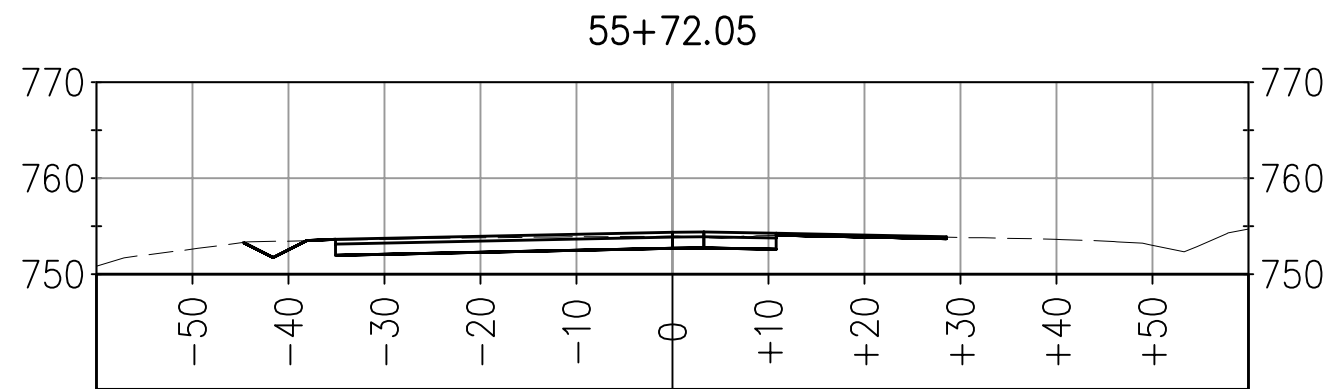
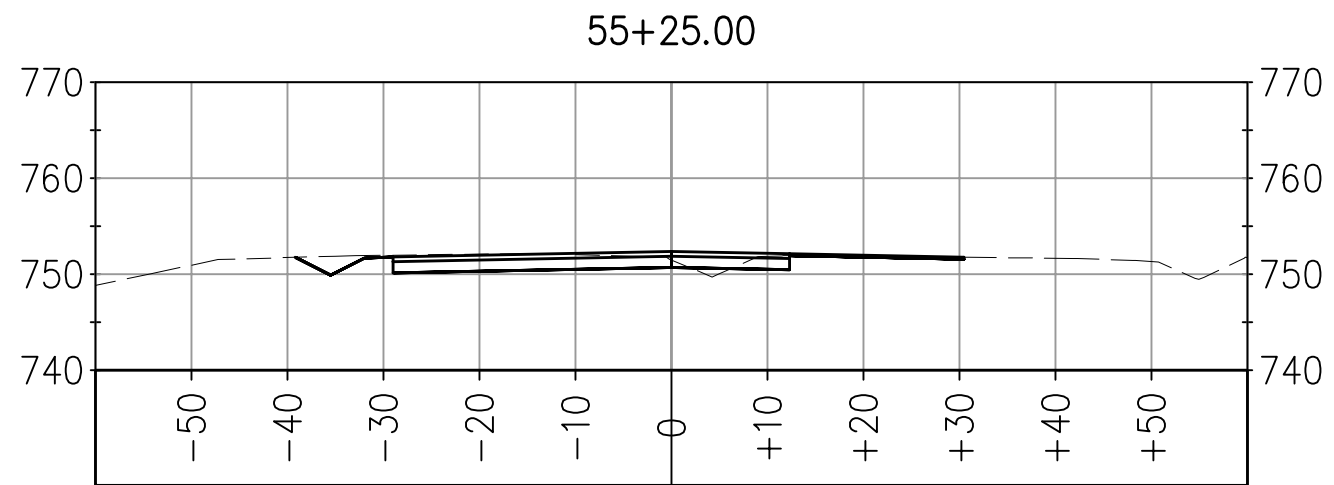

ALIGNMENT: SVP-F
 7-20-10
 DA
 SHEET 5 OF 6

MODEL DOES NOT INCLUDE THE FOLLOWING:
 RIP RAP
 DITCH TRANSITION
 AB LIMITS OFFSET FROM SAWCUT

SILVA VALLEY PARKWAY WIDENING SOUTH OF ENTRADA DRIVE #72370
 EL DORADO COUNTY DEPARTMENT OF TRANSPORTATION

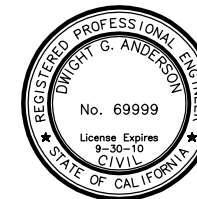

PREPARED UNDER THE SUPERVISION OF :

Dwight G. Anderson

REGISTERED CIVIL ENGINEER

7-20-10
 DATE:

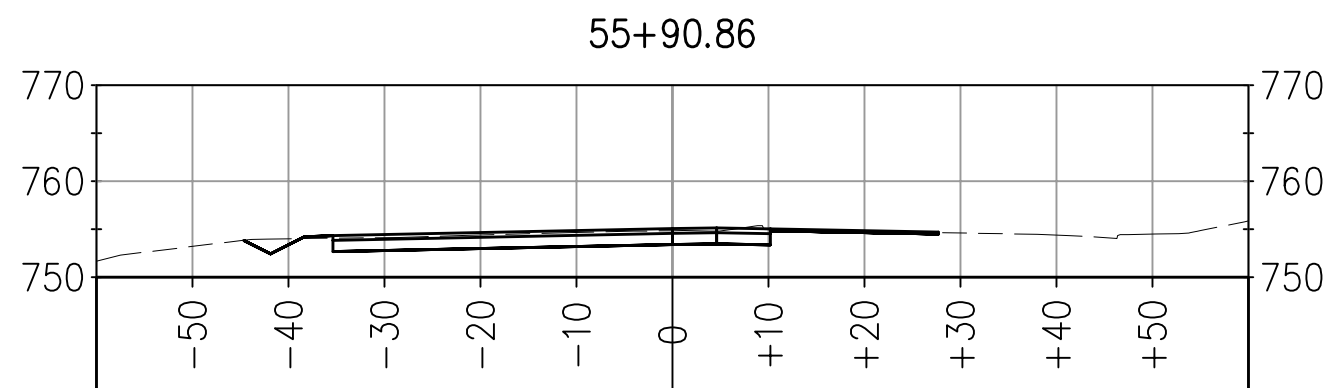
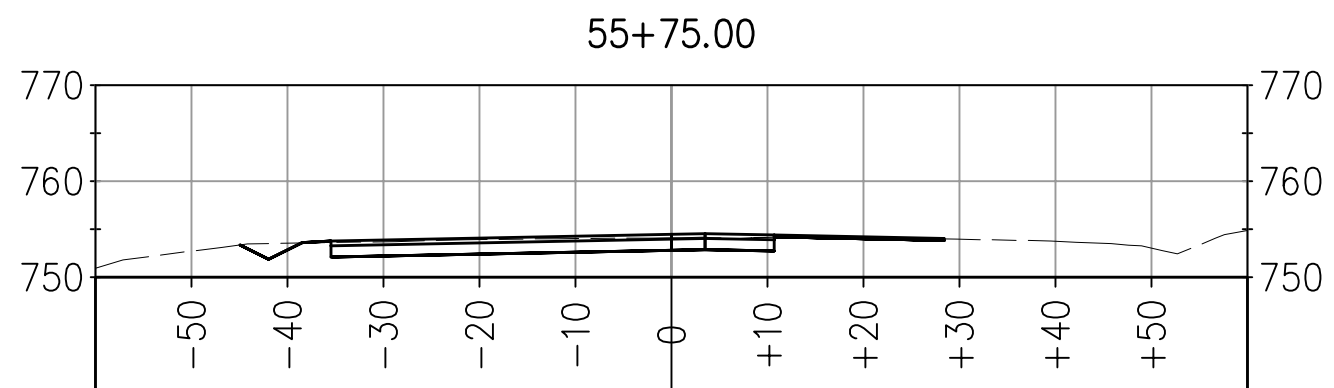
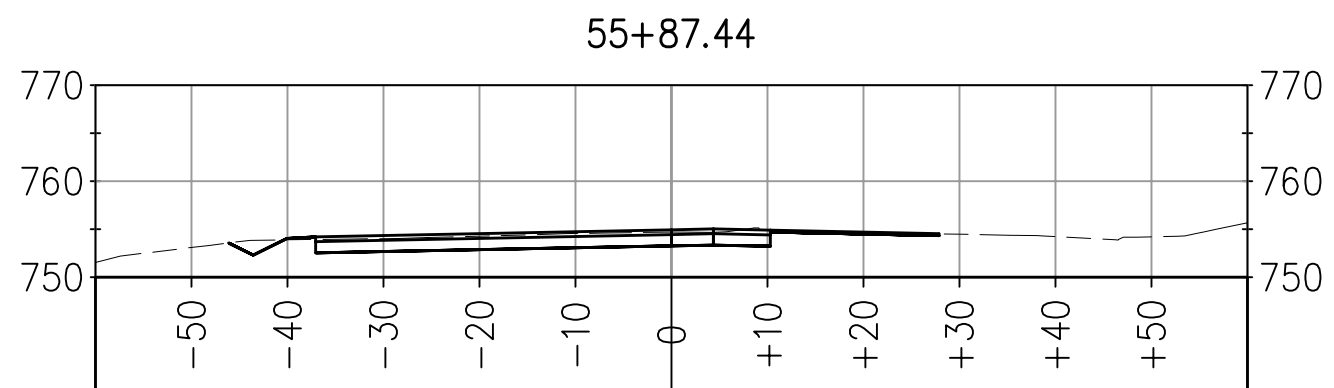
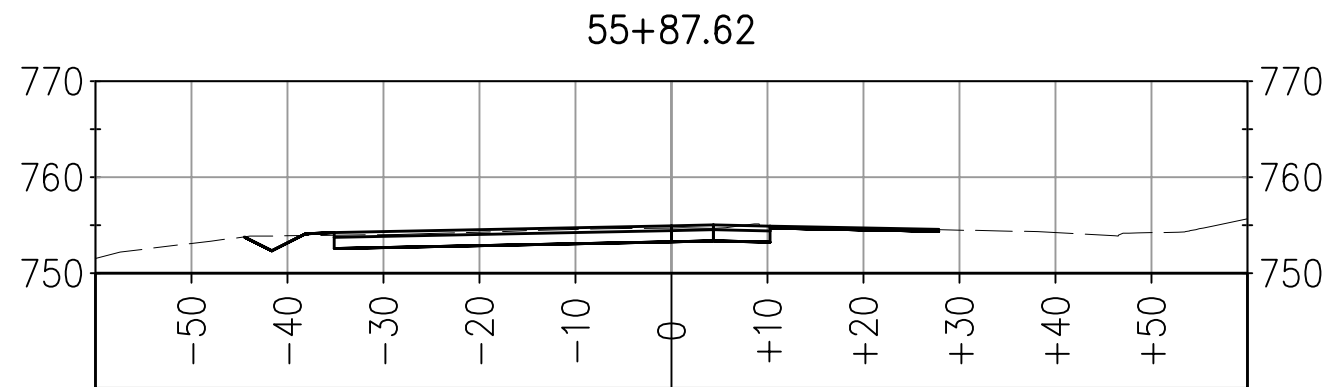

ALIGNMENT: SVP-F
 7-20-10
 DA
 SHEET 6 OF 6

MODEL DOES NOT INCLUDE THE FOLLOWING:
 RIP RAP
 DITCH TRANSITION
 AB LIMITS OFFSET FROM SAWCUT

SILVA VALLEY PARKWAY WIDENING SOUTH OF ENTRADA DRIVE #72370
 EL DORADO COUNTY DEPARTMENT OF TRANSPORTATION

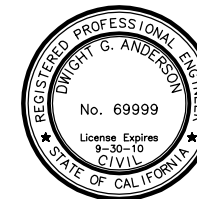

PREPARED UNDER THE SUPERVISION OF :

Dwight G. Anderson

REGISTERED CIVIL ENGINEER

7-20-10
 DATE: